

### XFP-10GB-BX-D-20-CN2-PRO

Ciena® Compatible TAA Compliant 10GBase-BX XFP Transceiver (SMF, 1330nmTx/1270nmRx, 20km, DOM, 0 to 70C, LC)

#### Features

- INF-8077i Compliance
- Simplex LC Connector
- Commercial Temperature 0 to 70 Celsius
- Single-mode Fiber
- Hot Pluggable
- Excellent ESD Protection
- Metal with Lower EMI
- RoHS Compliant and Lead Free



#### Applications:

- 10GBase-BX Ethernet
- 8x/10x Fibre Channel
- Access, Metro and Enterprise

#### Product Description

This Ciena® XFP transceiver provides 10GBase-BX throughput up to 20km over single-mode fiber (SMF) using a wavelength of 1330nmTx/1270nmRx via an LC connector. It is guaranteed to be 100% compatible with the equivalent Ciena® transceiver. This easy to install, hot swappable transceiver has been programmed, uniquely serialized and data-traffic and application tested to ensure that it will initialize and perform identically. Digital optical monitoring (DOM) support is also present to allow access to real-time operating parameters. This transceiver is Trade Agreements Act (TAA) compliant. We stand behind the quality of our products and proudly offer a limited lifetime warranty.

Proline's transceivers are RoHS compliant and lead-free.

TAA refers to the Trade Agreements Act (19 U.S.C. & 2501-2581), which is intended to foster fair and open international trade. TAA requires that the U.S. Government may acquire only "U.S. – made or designated country end products.



## Regulatory Compliance

- ESD to the Electrical PINs: compatible with MIL-STD-883E Method 3015.4
- ESD to the LC Receptacle: compatible with IEC 61000-4-2
- EMI/EMC compatible with FCC Part 15 Subpart B Rules, EN55022:2010
- Laser Eye Safety compatible with FDA21CFR, EN60950-1&EN (IEC) 60825-1,2
- RoHS compliant with EU RoHS Directive 2011/65/EU

## Absolute Maximum Ratings

Parameter	Symbol	Min.	Typ	Max.	Unit
Maximum Supply Voltage	Vcc	-0.5		4.0	V
Storage Temperature	TS	-40		85	°C
Operating Humidity	RH	0		85	%
Operating Temperature	Tc	0		70	°C
Data Rate (Gigabit Ethernet)		9.95	10	10.5	Gbps
9/125µm G.652 SMF	Lmax			20	km

## Electrical Characteristics

Parameter	Symbol	Min.	Typ.	Max.	Unit	Notes
Power Supply Voltage	Vcc	3.13	3.30	3.47	V	Vcc
Power Supply Current	Icc			350	mA	Icc
<b>Transmitter</b>						
Differential data input swing	Vin, pp	120	600	850	mV	
Input differential impedance	Zin	90	100	110	Ω	
TX Disable-High		2.0		Vcc+0.3	V	
TX Disable-Low		Vee-0.3		0.8	V	
TX Fault-High		2.0		Vcc+0.3	V	
TX Fault-Low		Vee-0.3		0.8	V	
<b>Receiver</b>						
Differential data output swing	Vout, pp	300	600	850	mV	
Output Differential Impedance	Zin	90	100	110	Ω	
LOS-High		2.0		Vcc+0.3	V	
LOS-Low		Vee-0.3		0.8	V	

## Optical Characteristics

Parameter	Symbol	Min.	Typ.	Max.	Unit	Notes
<b>Transmitter</b>						
Output Opt. Power	PO	1		6	dBm	1
Optical Wavelength	$\lambda$	1320	1330	1340	nm	
Spectral Width (-20dB)	$\sigma$			1	nm	
Extinction Ratio	ER	4			dB	
Average Power of OFF Transmitter				-40	dBm	
Eye Diagram		Compatible with IEEE 802.3-2005				
<b>Receiver</b>						
Center Wavelength	$\lambda_C$	1260	1270	1280	nm	
Receiver Sensitivity	PIN			-13	dBm	
Receiver Overload	Pmax	0.5			dBm	
LOS Hysteresis		0.5		5	dB	
LOS Assert	LOSA	-30			dBm	
LOS De-Assert	LOSD			-15	dBm	

### Note:

1. BER  $\leq 10^{-12}$  @PRBS231 -1 at 10.3125Gb/s

## Digital Diagnostic Functions

The digital diagnostic monitoring interface also defines another 256-byte memory map in EEPROM, which makes use of the 8 bit address 1010000X (A0h). The monitoring specification of the product is described in this table.

Parameter	Range	Accuracy	Calibration
Temperature	-5 to +85°C	$\pm 3^\circ\text{C}$	Internal
Voltage	2.97 to 3.63V	$\pm 3\%$	Internal
Bias Current	0 to 100mA	$\pm 10\%$	Internal
TX Power	1 to 6dBm	$\pm 2\text{dB}$	Internal
RX Power	-13 to 0.5dBm	$\pm 3\text{dB}$	internal

## Pin Descriptions

Pin	Symbol	Name/Descriptions	Ref.
1	GND	Module Ground	
2	Vee5	(not required)	
3	MOD_DESEL	Module De-select; When Held low allows the module to respond to 2-wire serial interface. LVTTTL-I	
4	/INTERRUPT	Interrupt; Indicates presence of an important condition which can be read via the 2-wire serial interface. LVTTTL-O	2
5	TX_DIS	Transmitter Disable. Logic1 indicates laser output disabled, LVTTTL-I	
6	VCC5	+5V Power Supply (Not required)	
7	GND	Module Ground	1
8	VCC3	+3.3V Power Supply	
9	VCC3	+3.3V Power Supply	
10	SCL	2-Wire Serial Interface Clock. LVTTTL-I	2
11	SDA	2-Wire Serial Interface Data Line. LVTTTL-I/O	2
12	MOD_Abs	Indicates Module is not present. Grounded in the Module. LVTTTL-O	2
13	MOD_NR	Module Not Ready; Indicating Module Operational Fault. Open-collector. LVTTTL-O	2
14	RX_LOS	Loss of Signal indication. Logic 1 indicates loss of Signal. Open-collector. LVTTTL-O	2
15	GND	Module Ground	1
16	GND	Module Ground	1
17	RD-	Receiver Inverted Data Output. CML-O	
18	RD+	Receiver Non-Inverted Data Output. CML-O	
19	GND	Module Ground	1
20	VCC2	+1.8V Power Supply (Not required).	3
21	P_DOWN/RST	Power down; When high, requires the module to limit power consumption to 1.5W or below. 2-Wire serial interface must be functional in the low power mode. LVTTTL-I Reset; The falling edge initiates a complete reset of the module including the 2-wire serial interface, equivalent to a power cycle. LVTTTL-I	
22	VCC2	+1.8V Power Supply (Not required)	3
23	GND	Module Ground	1
24	REFCLK+	Reference Clock (Not required)	
25	REFCLK-	Reference Clock (Not required)	
26	GND	Module Ground	1
27	GND	Module Ground	1
28	TD-	Transmitter Inverted Data Input. CML-I	
29	TD+	Transmitter Non-Inverted Data Input. CML-I	
30	GND	Module Ground	1

**Notes:**

1. Module ground pins GND are isolated from the module case and chassis ground within the module.
2. Open collector; should be pulled up with 4.7K-10Kohms to a voltage between 3.15V and 3.6V on the host board.
3. The pins are open within module.

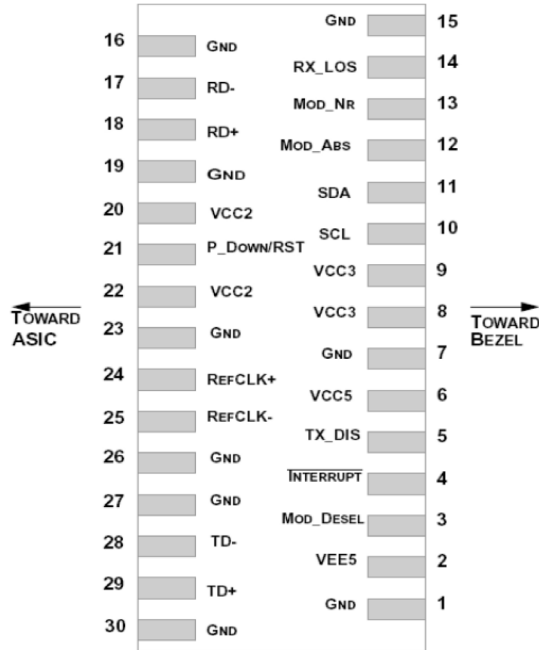

Pin-out of connector Block on Host board

### Recommend Circuit Schematic

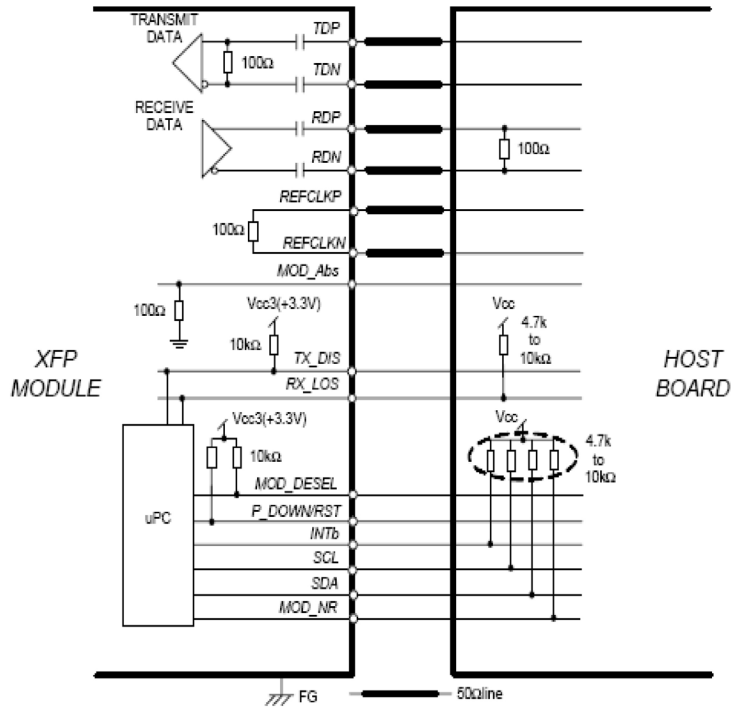

### Mechanical Specifications

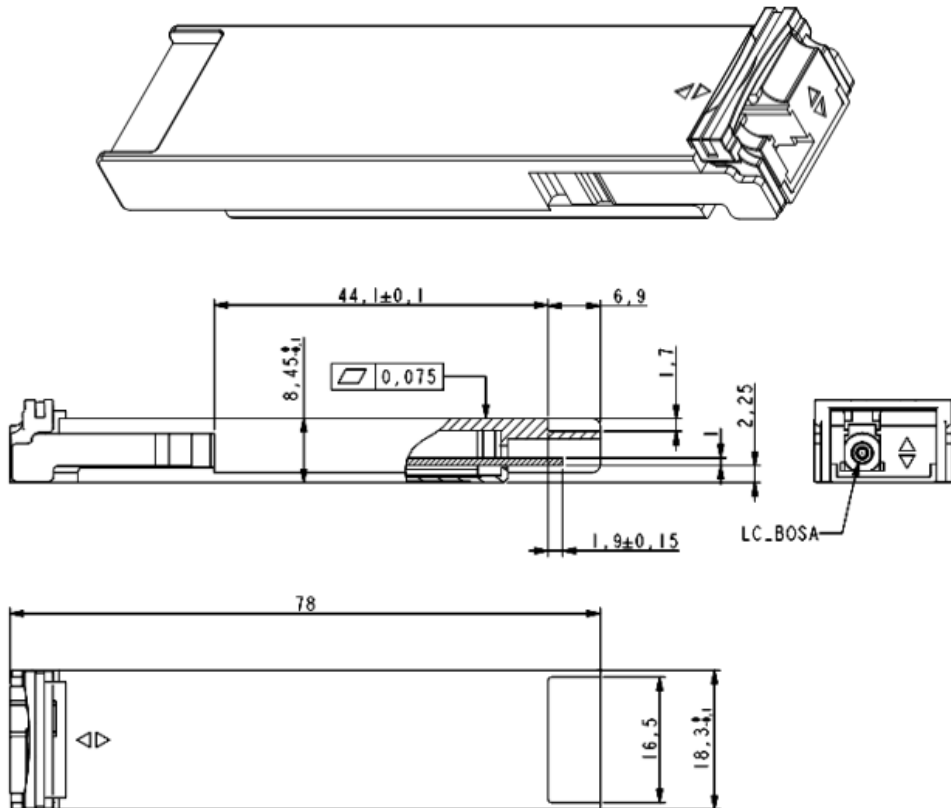

**About Us:**

Proline Options is one of North America's leading providers of transceivers and high speed cabling. With a reputation for quality, tested products that cover the connectivity spectrum, Proline Options has a solution for you regardless of the specification.

At Proline Options, every product is tested in its intended application - never batch or spec tested only. We run bandwidth, distance and IOS network tests. We have documented an impressive 0.03% failure rate over the last 10 years. To continue this rate of success we invest millions annually in our own on-site testing lab.



Tel: 855.933.3223

Email: [sales@prolineoptions.com](mailto:sales@prolineoptions.com)

Email: [techsupport@prolineoptions.com](mailto:techsupport@prolineoptions.com)

Web: <https://www.prolineoptions.com>