

XENPAK-SR-PRO

MSA and TAA Compliant 10GBase-SR XENPAK Transceiver (MMF, 850nm, 300m, DOM, 0 to 70C, SC)

Features

- INF-8474 Compliance
- Duplex SC Connector
- Commercial Temperature 0 to 70 Celsius
- Multi-mode Fiber
- Hot Pluggable
- Excellent ESD Protection
- Metal with Lower EMI
- RoHS Compliant and Lead Free



Applications:

- 10GBase-SR Ethernet
- 8x/10x Fibre Channel
- Access, Datacenter and Enterprise
- Mobile Fronthaul CPRI/OBSAI

Product Description

This MSA Compliant XENPAK transceiver provides 10GBase-SR throughput up to 300m over multi-mode fiber (MMF) using a wavelength of 850nm via a SC connector. It is built to MSA standards and is uniquely serialized and data-traffic and application tested to ensure that they will integrate into your network seamlessly. Digital optical monitoring (DOM) support is also present to allow access to real-time operating parameters. This transceiver is Trade Agreements Act (TAA) compliant. We stand behind the quality of our products and proudly offer a limited lifetime warranty.

Proline's transceivers are RoHS compliant and lead-free.

TAA refers to the Trade Agreements Act (19 U.S.C. & 2501-2581), which is intended to foster fair and open international trade. TAA requires that the U.S. Government may acquire only "U.S. – made or designated country end products.



Absolute Maximum Ratings

Parameter	Symbol	Min.	Max.	Unit
Maximum Supply Voltage	V _{CC}	-0.5	4.0	V
Storage Temperature	TS	-40	85	°C
Power Case Temperature		0	70	°C
Adaptable Power Supply	V _{apsense}	0	1.5	V

Recommended Operating Conditions

Parameter	Symbol	Min.	Typ.	Max.	Unit
Power Supply Voltage	V _{CC3}	3.13	3.30	3.47	V
	V _{APS}	1.152	1.2	1.248	
Power Supply Current	I _{CC}			300	mA
Case Operating Temperature – Commercial	T _C	0		70	°C
Power Dissipation	PD		1.7	2.4	W

Electrical Characteristics

Parameter	Symbol	Min.	Typ.	Max.	Unit	Notes
1.2 V CMOS						
Input High Voltage	V _{IL(MAX)}	120	600	850	mV	
Input Low Voltage	V _{IH(MIN)}	90	100	110	Ω	
Capacitance		2.0		V _{CC} +0.3	V	
Pull Up Resistance		V _{EE} -0.3		0.8	V	
MDIO I/O						
Output Low Voltage	V _{OL}	-0.3		0.2	V	
Output Low Current	I _{OL}			4	mA	
Input High Voltage	V _{IH}	0.84		1.5	V	
Input Low Voltage	V _{IL}	-0.3		0.36	V	
Pull-up Supply Voltage	V _{PULL}	1.14	1.2	1.26		
Input Capacitance	C _{IN}			10	Pf	
Load Capacitance	C _{LOAD}			470	Pf	
External Pull-up Resistance	E _{PULL}	200			Ohm	

Optical Characteristics

Parameter	Symbol	Min.	Typ.	Max.	Unit	Notes
Transmitter						
Operating Range				300	m	
Operating Data Rate			10.3125		Gb/s	
Average Optics Power	Po	-6.5		-1	dBm	
Input Centre Wavelength	λ	840	850	860	nm	
Spectral Width	$\Delta \lambda$			0.45	dB	
Extinction Ratio	ER	3.5	0.4			
Optical Modulation Amplitude	OMA	525			μ W	
Transmitter and Dispersion Penalty	TDP			3.2	dB	
Receiver						
Operating Data Rate			10.3125		Gb/s	
Average Receiver Power	Po	-9.9		-1.0	dBm	
Sensitivity in OMA	OMA0			-11.1	dBm	1
Stressed Sensitivity in OMA	OMAst			-7.5	dBm	

Notes:

1. Measured at 10.3125Gb/s, Non-framed PRBS2³¹-1, NRZ.

XAUI I/O Characteristics

Parameter	Symbol	Min.	Typ.	Max.	Unit	Notes
XAUI Data Rate	DR		3.125		Gb/s	
XAUI Baud Rate Tolerance		-100		100	Ppm	
Differential Input Voltage Swing		220		1600	Mv	
Differential Output Voltage Swing		800		1600	mVp-p	
Differential Input Impedance		80	100	120	Ω	
Total Output Jitter	TJXAUI			0.35	UI	
Total Deterministic Output Jitter	DJXAUI			0.17	UI	

Pin Descriptions

Pin	Symbol	Name/Descriptions	Ref.
1	GND	Electrical Ground.	1
2	GND	Electrical Ground.	2
3	GND	Electrical Ground.	3
4	5.0V	Power	
5	3.3V	Power	
6	3.3V	Power	4
7	APS =1.2V	Adaptive Power Supply.	5
8	APS =1.2V	Adaptive Power Supply.	2
9	LASI	Open Drain Compatible 10K-22K pull up on host. Logic High: Normal Operation Logic Low: LASI Asserted	5
10	RESET	Open Drain compatible. 10-22K pull-up on transceiver Logic high = Normal operation Logic low = Reset Minimum reset assert time 1 ms	1
11	VEND SPECIFIC	Vendor Specific Pin. Leave unconnected when not in use.	1
12	TX ON/OFF	Open Drain compatible. 10-22K pull-up on transceiver Logic high = Transmitter On (capable) Logic low = Transmitter Off (always)	
13	RESERVED	Reserved	
14	MODE DETECT	Pulled low inside module through 1k	1
15	VEND SPECIFIC	Vendor Specific Pin. Leave unconnected when not in use.	
16	VEND SPECIFIC	Vendor Specific Pin. Leave unconnected when not in use.	
17	MDIO	Management Data IO	1
18	MDC	Management Data Clock	
19	PRTAD4	Port Address Bit 4 (Low = 0)	
20	PRTAD3	Port Address Bit 3 (Low = 0)	1
21	PRTAD2	Port Address Bit 2 (Low = 0)	
22	PRTAD1	Port Address Bit 1 (Low = 0)	
23	PRTAD0	Port Address Bit 0 (Low = 0)	
24	VEND SPECIFIC	Vendor Specific Pin. Leave unconnected when not in use.	
25	APS SET	Feedback input for APS	

26	RESERVED	Reserved for Avalanche Photodiode use.	
27	APS SENSE	APS Sense Connection	
28	APS =1.2V	Adaptive Power Supply	
29	APS =1.2V	Adaptive Power Supply	
30	3.3V	Power	
31	3.3V	Power	
32	5.0V	Power	
33	GND	Electrical Ground	
34	GND	Electrical Ground	
35	GND	Electrical Ground	
36	GND	Electrical Ground	
37	GND	Electrical Ground	
38	RESERVED	Reserved	
39	RESERVED	Reserved	
40	GND	Electrical Ground	
41	RX LANE0+	Module XAUI Output Lane 0+	
42	RX LANE0-	Module XAUI Output Lane 0-	
43	GND	Electrical Ground	
44	RX LANE1+	Module XAUI Output Lane 1+	
45	RX LANE1-	Module XAUI Output Lane 1-	
46	GND	Electrical Ground	
47	RX LANE2+	Module XAUI Output Lane 2+	
48	RX LANE2-	Module XAUI Output Lane 2-	
49	GND	Electrical Ground	
50	RX LANE3+	Module XAUI Output Lane 3+	
51	RX LANE3-	Module XAUI Output Lane 3-	
52	GND	Electrical Ground	
53	GND	Electrical Ground	
54	GND	Electrical Ground	
55	TX LANE0+	Module XAUI Input Lane 0+	
56	TX LANE0-	Module XAUI Input Lane 0-	
57	GND	Electrical Ground	
58	TX LANE1+	Module XAUI Input Lane 1+	
59	TX LANE1-	Module XAUI Input Lane 1-	
60	GND	Electrical Ground	

61	TX LANE2+	Module XAUI Input Lane 2+	
62	TX LANE2-	Module XAUI Input Lane 2-	
63	GND	Electrical Ground	
64	TX LANE3+	Module XAUI Input Lane 3+	
65	TX LANE3	Module XAUI Input Lane 3	
66	GND	Electrical Ground	
67	RESERVED	Reserved	
68	RESERVED	Reserved	
69	GND	Electrical Ground	
70	GND	Electrical Ground	

Notes:

1. Ground connections are common for TX and RX.
2. All connector contacts are rated at 0.5A nominal.
3. 1.2V CMOS compatible.
4. MDIO and MDC timing must comply with IEEE802.3ae, Clause 45.3.
5. XAUI output characteristics should comply with IEEE802.3ae Clause 47.
6. Transceivers will be MSA compliant when no signals are present on the vendor specific pins.

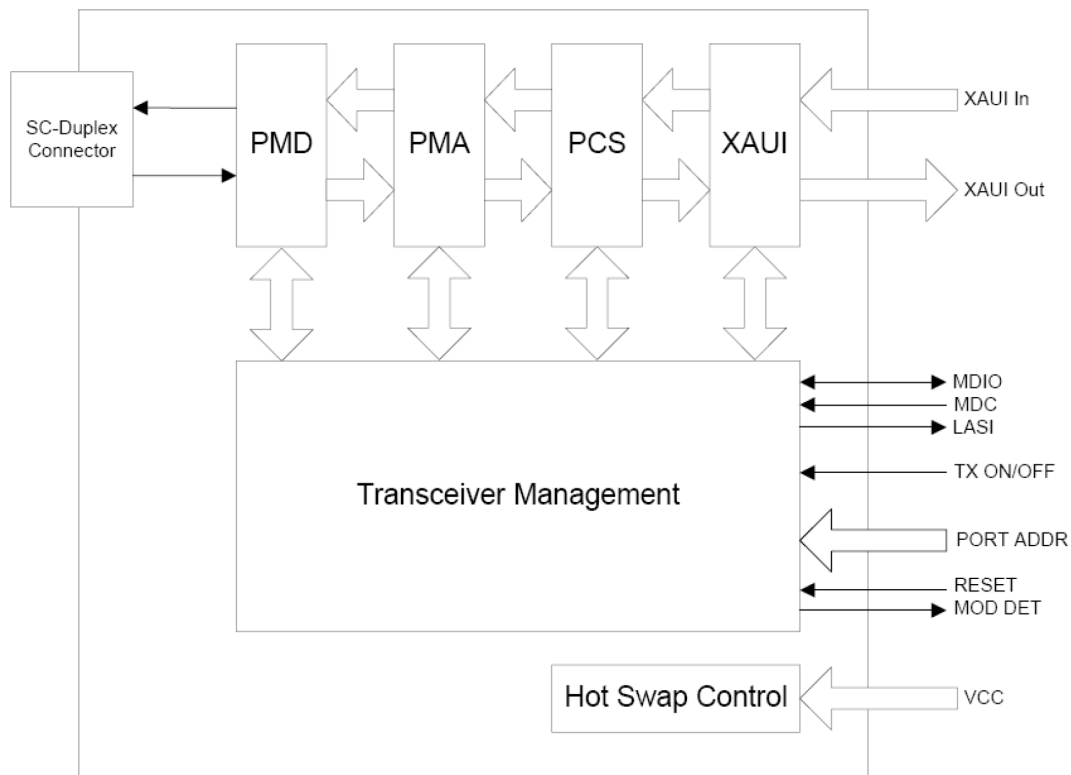

Functional Diagram of Typical XENPAK Style Transceiver

Electrical Pin-out Details



70	GND
69	GND
68	RESERVED
67	RESERVED
66	GND
65	TX LANE3-
64	TX LANE3+
63	GND
62	TX LANE2-
61	TX LANE2+
60	GND
59	TX LANE1-
58	TX LANE1+
57	GND
56	TX LANE0-
55	TX LANE0+
54	GND
53	GND
52	GND
51	RX LANE3-
50	RX LANE3+
49	GND
48	RX LANE2-
47	RX LANE2+
46	GND
45	RX LANE1-
44	RX LANE1+
43	GND
42	RX LANE0-
41	RX LANE0+
40	GND
39	RESERVED
38	RESERVED
37	GND
36	GND

1	GND
2	GND
3	GND
4	5.0V
5	3.3V
6	3.3V
7	APS
8	APS
9	LASI
10	RESET
11	VEND SPECIFIC
12	TX ON/OFF
13	RESERVED
14	MOD DETECT
15	VEND SPECIFIC
16	VEND SPECIFIC
17	MDIO
18	MDC
19	PRTAD4
20	PRTAD3
21	PRTAD2
22	PRTAD1
23	PRTAD0
24	VEND SPECIFIC
25	APS SET
26	RESERVED
27	APS SENSE
28	APS
29	APS
30	3.3V
31	3.3V
32	5.0V
33	GND
34	GND
35	GND

Mechanical Dimensions

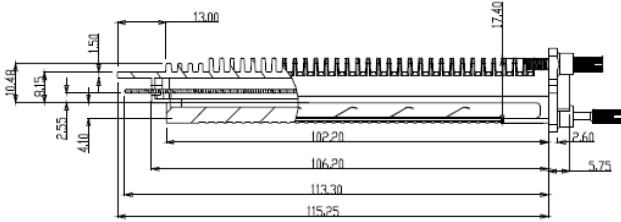
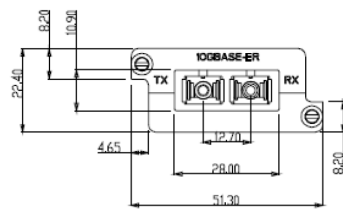
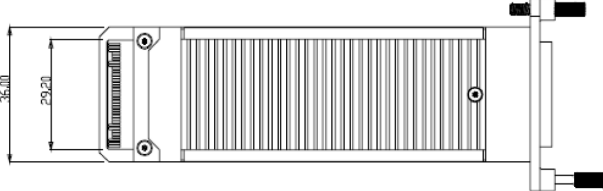
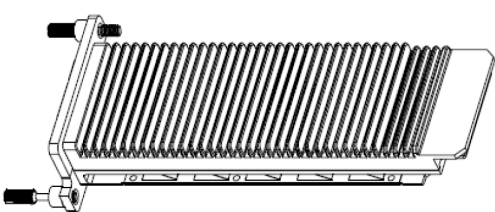

About Us:

Proline Options is one of North America's leading providers of transceivers and high speed cabling. With a reputation for quality, tested products that cover the connectivity spectrum, Proline Options has a solution for you regardless of the specification.

At Proline Options, every product is tested in its intended application - never batch or spec tested only. We run bandwidth, distance and IOS network tests. We have documented an impressive 0.03% failure rate over the last 10 years. To continue this rate of success we invest millions annually in our own on-site testing lab.



Tel: 855.933.3223

Email: sales@prolineoptions.com

Email: techsupport@prolineoptions.com

Web: <https://www.prolineoptions.com>