

XCVR-B00CRJ-C-PRO

Ciena® XCVR-B00CRJ-C Compatible TAA Compliant 10/100/1000Base-TX SFP Transceiver (Copper, 100m, 0 to 70C, RJ-45)

Features

- INF-8074 Compliance
- Copper Media Type
- RJ-45 Connector
- Commercial Temperature 0 to 70 Celsius
- Hot Pluggable
- Support for LOS indication function configuration
- Excellent ESD Protection
- Metal with Lower EMI
- RoHS Compliant and Lead Free



Applications:

- 1000Base Ethernet
- Access and Enterprise

Product Description

This Ciena® XCVR-B00CRJ-C compatible SFP transceiver provides 10/100/1000Base-TX throughput up to 100m over a copper connection via a RJ-45 connector. This TX module supports 10/100/1000Base auto-negotiation and can be configured to fit your needs. It is guaranteed to be 100% compatible with the equivalent Ciena® transceiver. This easy to install, hot swappable transceiver has been programmed, uniquely serialized and data-traffic and application tested to ensure that it will initialize and perform identically. It is built to meet or exceed the specifications of Ciena®, as well as to comply with MSA (Multi-Source Agreement) standards to ensure seamless network integration. This transceiver is Trade Agreements Act (TAA) compliant. We stand behind the quality of our products and proudly offer a limited lifetime warranty.

Proline's transceivers are RoHS compliant and lead-free.

TAA refers to the Trade Agreements Act (19 U.S.C. & 2501-2581), which is intended to foster fair and open international trade. TAA requires that the U.S. Government may acquire only "U.S. – made or designated country end products.



Absolute Maximum Ratings

Parameter	Symbol	Min.	Typ.	Max.	Unit	Notes
Maximum Supply Voltage	Vcc	-0.5		4.0	V	
Storage Temperature	Tstg	-40		85	°C	1
Operating Case Temperature	Tc	0	25	70	°C	1
Relative Humidity	RH	5		95	%	
Data Rate (Auto Working Mode)			1000		Mbps	
Data Rate (SGMII Working Mode)			10/100/1000		Mbps	
Data Rate (Full Working Mode)			1000		Mbps	

Notes:

1. Ambient temperature.
2. Case temperature.

Electrical Specifications

Parameter	Symbol	Min.	Typ.	Max.	Unit	Notes
Supply Voltage	Vcc	3.135	3.3	3.465	V	
Module Supply Current	Icc			400	mA	
Transmitter Differential Input Voltage (TD +/-)		500		2400	mVp-p	1
Receiver Differential Output Voltage (RD +/-)		500		2000	mVp-p	2
Differential Input Impedance		80	100	120	Ω	
Low-Speed Output: Transmitter Fault (Tx_Fault)/Loss of Signal (LOS)	VOH	2.0		Vcc	V	3
	VOL	0		0.8	V	
Low-Speed Input: Transmitter Disable (Tx_Disable), MOD_DEF 1, MOD_DEF 2	VIH	2.0		Vcc	V	4
	VIL	0		0.8	V	
Data Output Rise/Fall Time	Tr/Tf		180		ps	

Notes:

1. Internally AC coupled and terminated to 100Ω differential load.
2. Internally AC coupled but requires a 100Ω differential termination or internal to Serializer/Deserializer.
3. Pulled up externally with a 4.7kΩ-10kΩ resistor on the host board to VccT/R.
4. MOD_DEF1 and MOD_DEF2 must be pulled up externally with a 4.7kΩ-10kΩ resistor on the host board to VccT/R.

Pin Descriptions

Pin	Symbol	Name/Description	Note
1	VeeT	Transmitter Ground.	
2	Tx_Fault	Transmitter Fault Indication.	1
3	Tx_Disable	Transmitter Disable - Module disables on "high" or "open."	2
4	MOD_DEF2	Module Definition 2 - 2-Wire Serial ID Interface.	3
5	MOD_DEF1	Module Definition 1 - 2-Wire Serial ID Interface.	3
6	MOD_DEF0	Module Definition 0 - Grounded in the module.	3
7	Rate Select	Not Connected.	
8	LOS	Loss of Signal.	4
9	VeeR	Receiver Ground.	
10	VeeR	Receiver Ground.	
11	VeeR	Receiver Ground.	
12	RD-	Inverse Received Data Out.	5
13	RD+	Received Data Out.	5
14	VeeR	Receiver Ground.	
15	VccR	Receiver Power - +3.3V±5%.	6
16	VccT	Transmitter Power - +3.3 V±5%.	6
17	VeeT	Transmitter Ground.	
18	TD+	Transmitter Data In.	7
19	TD-	Inverse Transmitter Data In.	7
20	VeeT	Transmitter Ground.	

Notes:

- Tx_Fault is an open collector/drain output which should be pulled up externally with a 4.7kΩ-10kΩ resistor on the host board to supply $V_{ccT}+0.3V$ or $V_{ccR}+0.3V$. When "high," this output indicates a laser fault of some kind. "Low" indicates normal operation. In the low state, the output will be pulled to <math><0.8V</math>.
- Tx_Disable input is used to shut down the laser output per the state table below. It is pulled up within the module with a 4.7kΩ-10kΩ resistor.

Low (0 – 0.8V):	Transmitter On
Between (0.8V and 2V):	Undefined
High (2.0VccT):	Transmitter Disabled
Open:	Transmitter Disabled
- MOD_DEF 0, 1, 2. These are the module definition pins. They should be pulled up with a 4.7kΩ-10kΩ resistor on the host board to supply less than $V_{ccT}+0.3V$ or $V_{ccR}+0.3V$.
 - MOD_DEF 0 is grounded by the module to indicate that the module is present.
 - MOD_DEF 1 is clock line of 2-wire serial interface for optional serial ID.
 - MOD_DEF 2 is data line of 2-wire serial interface for optional serial ID.
- Support for LOS indication function configuration.
- RD-/+: These are the differential receiver outputs. They are AC coupled 100Ω differential lines which should be terminated with 100Ω differential at the user SERDES. The AC coupling is done inside the module and is thus not required on the host board.

6. VccR and VccT are the receiver and transmitter power supplies. They are defined as $3.3V \pm 5\%$ at the SFP connector pin. The in-rush current will typically be no more than 30mA above steady state supply current after 500ns.
7. TD-/+ : These are the differential transmitter inputs. They are AC coupled differential lines with 100Ω differential termination inside the module. The AC coupling is done inside the module and is thus not required on host board.

Electrical Pad Layout

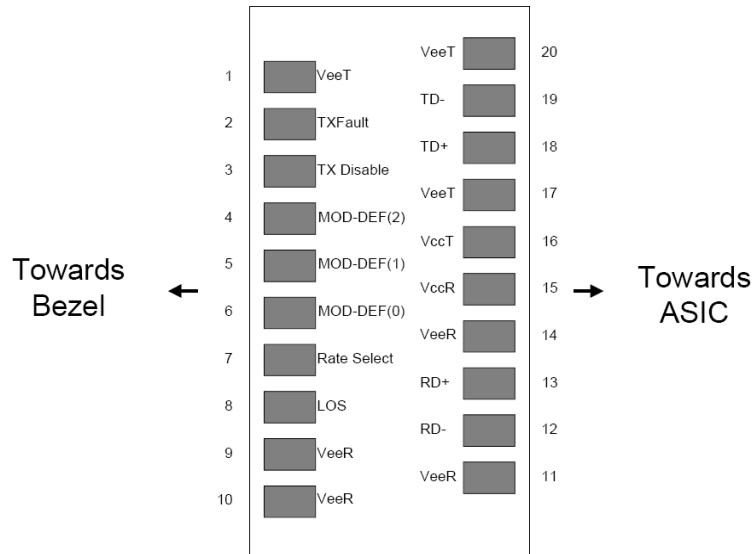

Required Host Board Components

The MSA power supply noise rejection filter is required on the host PCB to meet data sheet performance. The MSA filter incorporates an inductor which should be rated 400mA DC and 1Ω serial resistance or better. It should not be replaced with a ferrite. The required filter is illustrated in figure below.

The MSA also specifies that 4.7kΩ-10kΩ pull-up resistors for Tx_Fault, LOS, and MOD_DEF 0, 1, 2 are required on the host PCB. The figure below is the suggested transceiver/host interface.

The figure below shows the recommended host board power supply circuit.

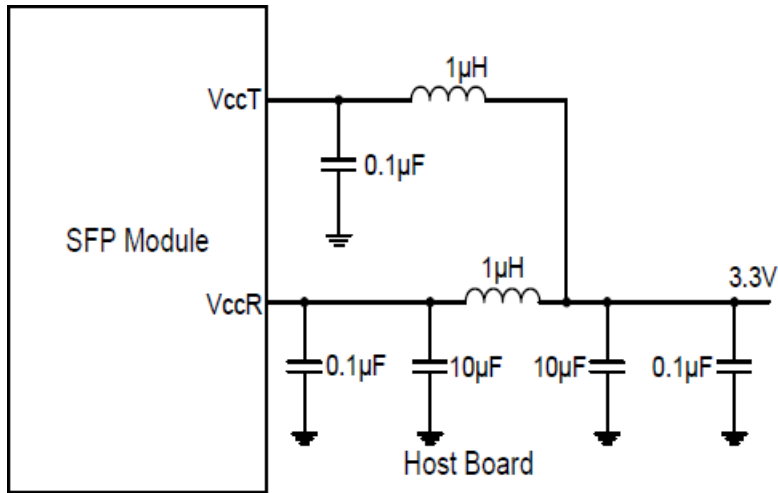

Recommended Application Interface Circuit

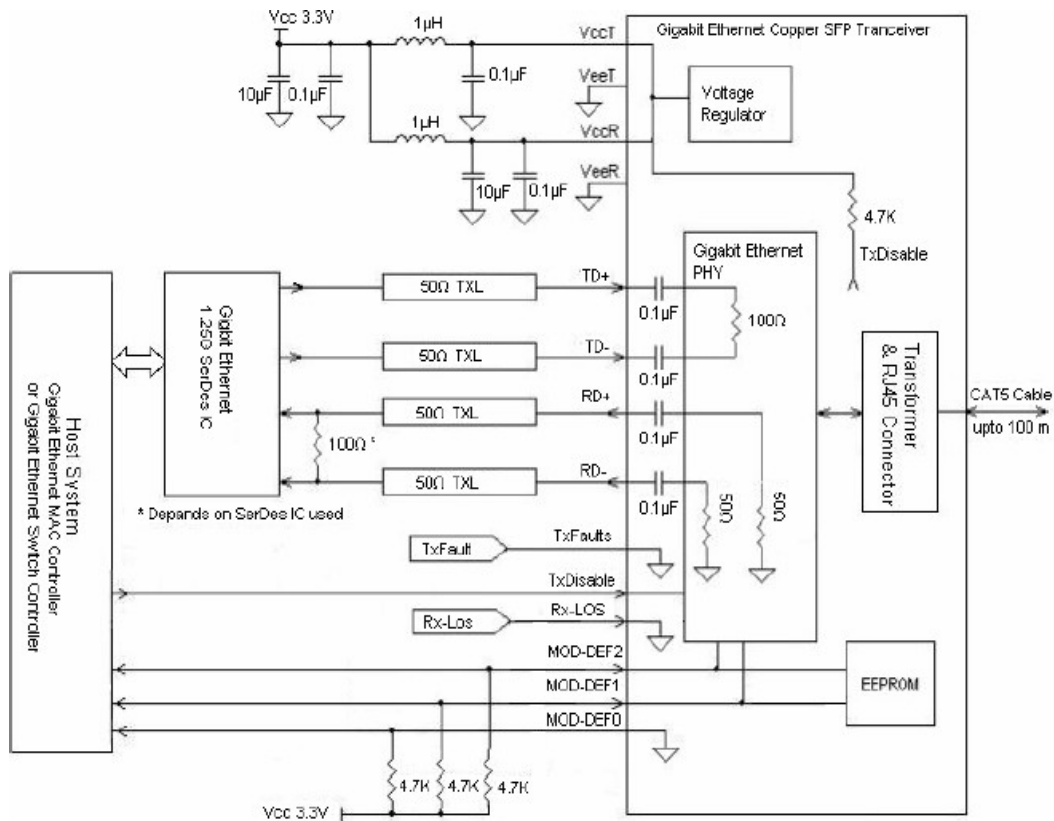

Mechanical Specifications

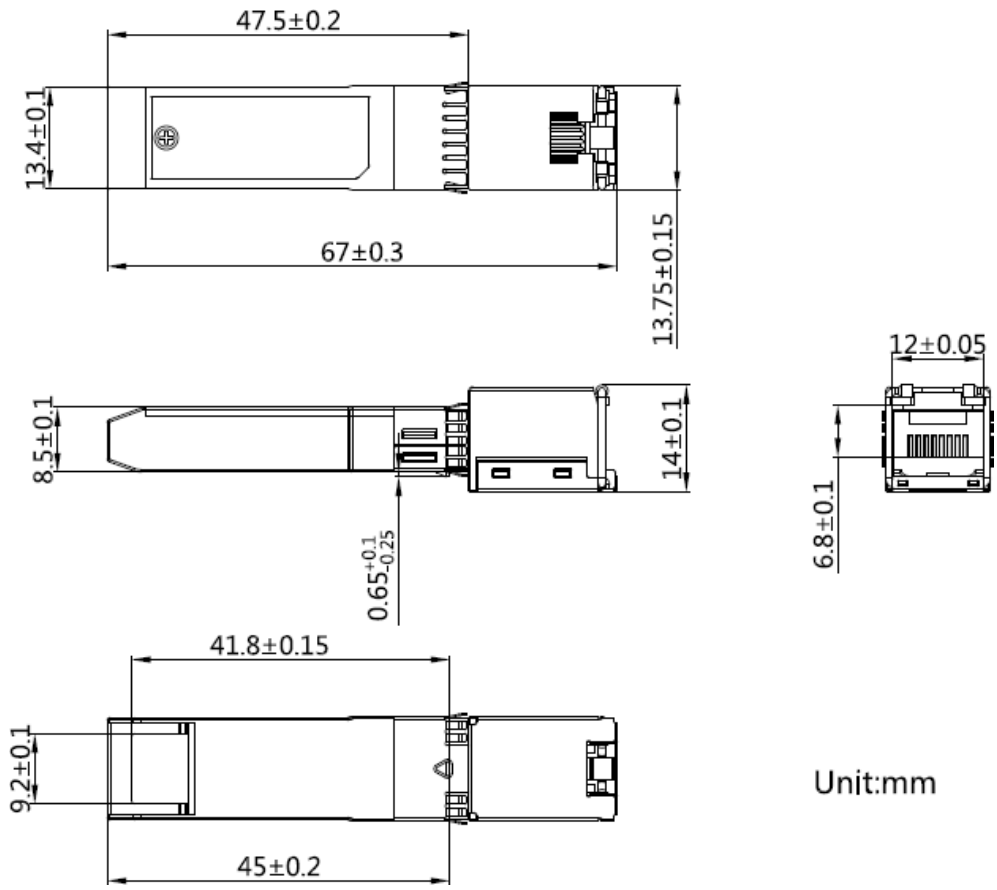

Unit:mm

About Us:

Proline Options is one of North America's leading providers of transceivers and high speed cabling. With a reputation for quality, tested products that cover the connectivity spectrum, Proline Options has a solution for you regardless of the specification.

At Proline Options, every product is tested in its intended application - never batch or spec tested only. We run bandwidth, distance and IOS network tests. We have documented an impressive 0.03% failure rate over the last 10 years. To continue this rate of success we invest millions annually in our own on-site testing lab.



Tel: 855.933.3223

Email: sales@prolineoptions.com

Email: techsupport@prolineoptions.com

Web: <https://www.prolineoptions.com>