

SFP-1G-BX35-U-80-I-PRO

MSA and TAA Compliant 1000Base-BX SFP Transceiver (SMF, 1310nmTx/1550nmRx, 80km, DOM, -40 to 85C, LC)

Features

- INF-8074 and SFF-8472 Compliance
- Simplex LC Connector
- Industrial Temperature -40 to 85 Celsius
- Single-mode Fiber
- Hot Pluggable
- Excellent ESD Protection
- Metal with Lower EMI
- RoHS Compliant and Lead Free



Applications:

- 1000Base Ethernet
- Access and Enterprise

Product Description

This MSA Compliant SFP transceiver provides 1000Base-BX throughput up to 80km over single-mode fiber (SMF) using a wavelength of 1310nmTx/1550nmRx via an LC connector. It is built to MSA standards and is uniquely serialized and data-traffic and application tested to ensure that they will integrate into your network seamlessly. Digital optical monitoring (DOM) support is also present to allow access to real-time operating parameters. This transceiver is Trade Agreements Act (TAA) compliant. We stand behind the quality of our products and proudly offer a limited lifetime warranty.

Proline's transceivers are RoHS compliant and lead-free.

TAA refers to the Trade Agreements Act (19 U.S.C. & 2501-2581), which is intended to foster fair and open international trade. TAA requires that the U.S. Government may acquire only "U.S. – made or designated country end products.



Absolute Maximum Ratings

Parameter	Symbol	Min.	Typ.	Max.	Unit	Notes
Maximum Supply Voltage	Vcc	-0.5		4.0	V	
Storage Temperature	Tstg	-40		85	°C	
Operating Case Temperature	Tc	-40	25	85	°C	
Operating Relative Humidity	RH	5		95	%	
Power Supply Current	Icc			300	mA	
Data Rate		0.1		1.25	Gbps	

Electrical Characteristics

Parameter	Symbol	Min.	Typ.	Max.	Unit	Notes
Supply Voltage	Vcc	3.135	3.3	3.465	V	
Module Supply Current	Icc			300	mA	
Power dissipation	Pd			1000	mW	
Transmitter Differential Input Voltage (TD+/-)		300		2200	mVp-p	1
Receiver Differential Output Voltage (RD+/-)		600		1200	mVp-p	2
Low speed output: Transmitter Fault (Tx_Fault)/ Loss of Signal(LOS)	Voh	2.0		Vcc	V	3
	Vol	0		0.8	V	
Low speed input: Transmitter Fault (Tx_Fault), Mod_Def1, Mod_Def2	Vih	2.0		Vcc	V	4
	Vil	0		0.8	V	
Timing Characteristics						
Tx_Disable Assert Time	T_off			10	us	
Tx_Disable Negate Time	T_on			1	ms	
Time to Initialize, Include reset of Tx_Fault	T_init			300	ms	
Tx_Fault from Fault to Assertion	T_fault			100	us	
Tx_Disable Time to Start Reset	T_reset	10			us	
Receiver LOS Assert Timer(On to Off)	T_D, Rx_LOS			80	us	
Receiver LOS Assert Timer(Off to On)	T_A, Rx_LOS			80	us	
Serial I2C Clock Rate	I2C_Clock			100	kHz	

Notes:

1. Internally AC coupled and terminated to 100Ω differential load.
2. Internally AC coupled, but requires a 100Ω differential termination or internal to Serializer/Deserializer.
3. Pulled up externally with a 4.7kΩ-10kΩ resistor on the host board to VccT,R.
4. Mod_Def1 and Mod_Def2 must be pulled up externally with a 4.7kΩ-10kΩ resistor on the host board to VccT,R.

Optical Characteristics

Parameter	Symbol	Min.	Typ.	Max.	Unit	Notes
Transmitter						
Launch Optical Power	Po	0		5	dBm	
Center Wavelength	λ_c	1260	1310	1360	nm	
Extinction Ratio	EX	9			dB	
Spectral Width (-20dB)	$\Delta\lambda$			1	Nm	
Side Mode Suppression Ratio	SMSR	30			dB	
Optical Rise/Fall Time	Trise/Tfall			260	Ps	
Pout @Tx-Disable Asserted	Poff			-45	dBm	
Eye Diagram	IEEE Std 802.3-2005 1000Base-BX-D compatible					
Receiver						
Wavelength Range		1470	1550	1600	nm	
Receiver Sensitivity	S			-26	dBm	1
Receiver Overload	Pol	-3			dBm	1
Optical Return Loss	ORL	12			dB	
LOS De-Assert	LOSd			-27	dBm	
LOS Assert	LOSa	-35			dBm	
LOS Hysteresis		0.5	3	5	dB	

Notes:

1. Measured with a PRBS 2^7-1 test pattern, 1.25Gbps, BER< 10^{-12} .

Pin Descriptions

Pin	Symbol	Name/Descriptions	Plug Seq.	Notes
1	VeeT	Transmitter Ground.	1	
2	Tx_Fault	Transmitter Fault Indication.	3	1
3	Tx_Disable	Transmitter Disable. Module disables on “high” or “open.”	3	2
4	MOD-DEF2	Module Definition 2. 2-Wire Serial ID Interface.	3	3
5	MOD-DEF1	Module Definition 1. 2-Wire Serial ID Interface.	3	3
6	MOD-DEF0	Module Definition 0. Grounded within the module.	3	3
7	Rate Select	Not Connected. Function not available.	3	
8	LOS	Loss of Signal.	3	4
9	VeeR	Receiver Ground.	1	
10	VeeR	Receiver Ground.	1	
11	VeeR	Receiver Ground.	1	
12	RD-	Inverse Received Data out.	3	5
13	RD+	Received Data out.	3	5
14	VeeR	Receiver Ground.	1	
15	VccR	3.3 ± 5% Receiver Power.	2	6
16	VccT	3.3 ± 5% Transmitter Power.	2	6
17	VeeT	Transmitter Ground.	1	
18	TD+	Transmitter Data In.	3	7
19	TD-	Inverse Transmitter Data In.	3	7
20	VeeT	Transmitter Ground.	1	

Notes:

- TX Fault is an open collector/drain output, which should be pulled up with a 4.7KΩ–10KΩ resistor on the host board. Pull up voltage between 2.0V and VccT/R+0.3V. When “high,” output indicates a laser fault of some kind. Low indicates normal operation. In the low state, the output will be pulled to < 0.8V.
- Tx_Disable is an input that is used to shut down the transmitter optical output. It is pulled up within the module with a 4.7kΩ–10kΩ resistor. Its states are:
 - Low (0 – 0.8V): Transmitter On.
 - Between (0.8 and 2.0V): Undefined.
 - High (2.0 – VccT): Transmitter Disabled.
 - Open: Transmitter Disabled.
- MOD-DEF0, 1, 2. These are the module definition pins. They should be pulled up with a 4.7kΩ–10kΩ resistor on the host board. The pull-up voltage shall be VccT or VccR.
 - MOD-DEF 0 is grounded by the module to indicate that the module is present.
 - MOD-DEF 1 is the clock line of 2-wire serial interface for optional serial ID.
 - MOD-DEF 2 is the data line of 2-wire serial interface for optional serial ID.
- LOS (Loss of Signal) is an open collector/drain output, which should be pulled up with a 4.7KΩ–10KΩ

resistor on the host board to supply $<V_{ccT}+0.3V$ or $V_{ccR}+0.3V$. When “high,” this output indicates the received optical power is below the worst-case receiver Sensitivity (as defined by the standard in use). Low indicates normal operation. In the low state, the output will be pulled to $< 0.8V$.

5. RD-/+ : These are the differential receiver outputs. They are AC coupled 100Ω differential Lines which should be terminated with 100Ω (differential) at the user SERDES. The AC coupling is done inside the module and is thus not required on the host board.
6. VccR and VccT are the receiver and transmitter power supplies. They are defined as $3.3V\pm 5\%$ at the SFP connector pin. The in rush current will typically be more than 30mA above steady state supply current after 500ns.
7. TD-/+ : These are the differential transmitter inputs. They are AC-coupled, differential lines with 100Ω differential terminations inside the module. They are AC coupled differential lines with 100Ω differential termination inside the module. The AC coupling is done inside the module and is thus requires on host board.

Pin Connectors

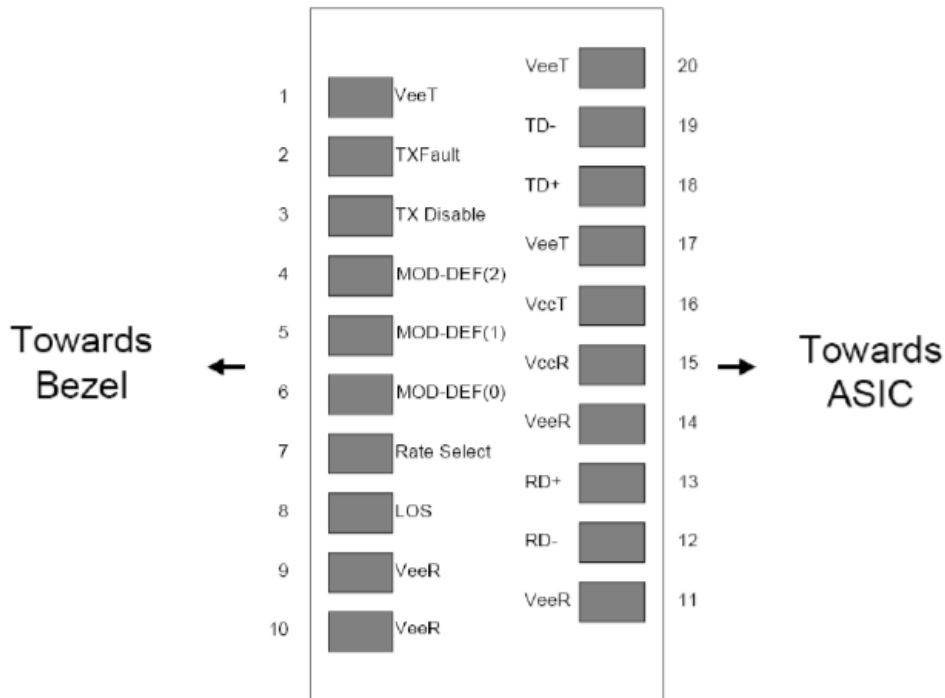

Recommended Host Board Power Supply Circuit

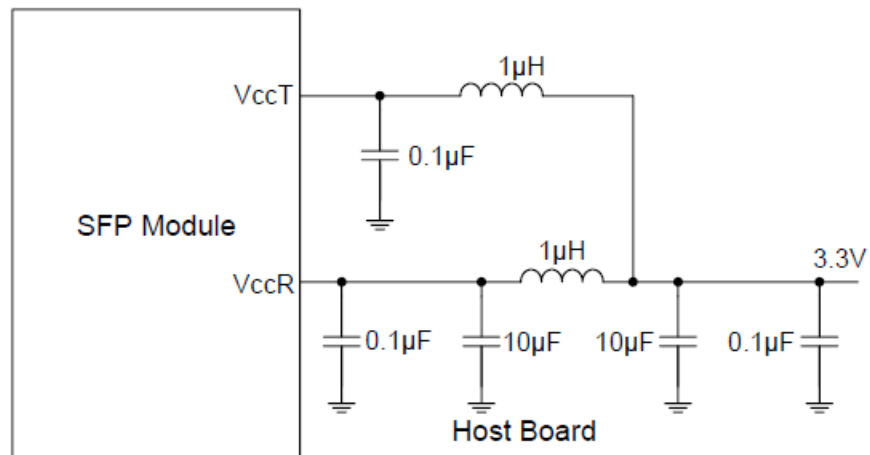

Recommended Application Interface Circuit

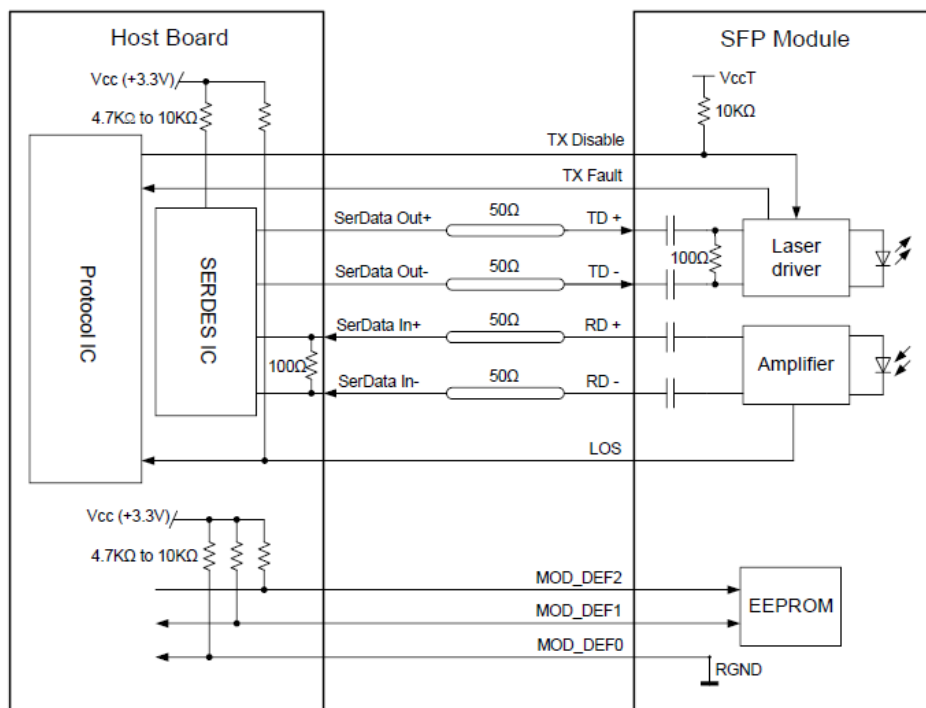

Mechanical Specifications

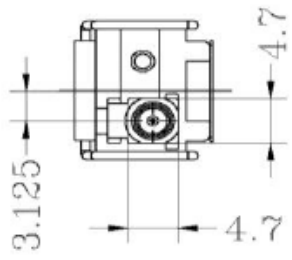

Unit:mm

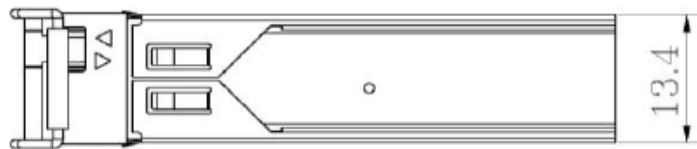
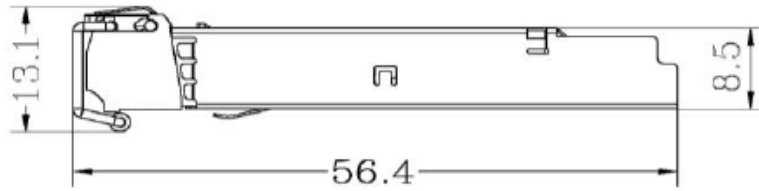
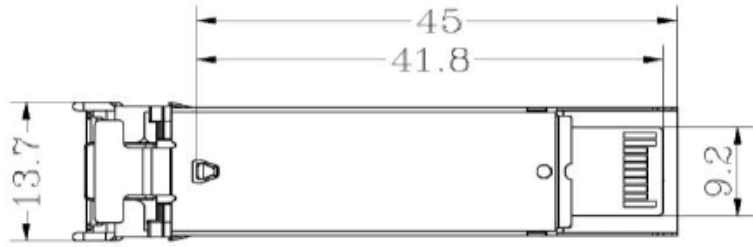

About Us:

Proline Options is one of North America's leading providers of transceivers and high speed cabling. With a reputation for quality, tested products that cover the connectivity spectrum, Proline Options has a solution for you regardless of the specification.

At Proline Options, every product is tested in its intended application - never batch or spec tested only. We run bandwidth, distance and IOS network tests. We have documented an impressive 0.03% failure rate over the last 10 years. To continue this rate of success we invest millions annually in our own on-site testing lab.



Tel: 855.933.3223

Email: sales@prolineoptions.com

Email: techsupport@prolineoptions.com

Web: <https://www.prolineoptions.com>