

SFP-10GB-D20-28-40-I-PRO

MSA and TAA Compliant 10GBase-DWDM 100GHz SFP+ Transceiver (SMF, 1561.42nm to 1554.94nm, 40km, DOM, -40 to 85C, LC)

Features

- SFF-8432 and SFF-8472 Compliance
- Integrated Tunable MZM transmitter and APD receiver
- Duplex LC Connector
- Single-mode Fiber
- Industrial Temperature -40 to 85 Celsius
- 8 Channels C-band (100GHz spacing)
- Metal with Lower EMI
- Hot Pluggable
- RoHS Compliant and Lead Free
- Excellent ESD Protection



Applications:

- 10x Gigabit Ethernet over DWDM
- 8x/10x Fibre Channel
- Access, Metro and Enterprise

Product Description

This MSA Compliant SFP+ transceiver provides 10GBase-DWDM throughput up to 40km over single-mode fiber (SMF) using a wavelength of 1561.42nm to 1554.94nm via an LC connector. It is built to MSA standards and is uniquely serialized and data-traffic and application tested to ensure that they will integrate into your network seamlessly. Digital optical monitoring (DOM) support is also present to allow access to real-time operating parameters. This transceiver is Trade Agreements Act (TAA) compliant. We stand behind the quality of our products and proudly offer a limited lifetime warranty.

Proline's transceivers are RoHS compliant and lead-free.

TAA refers to the Trade Agreements Act (19 U.S.C. & 2501-2581), which is intended to foster fair and open international trade. TAA requires that the U.S. Government may acquire only "U.S. – made or designated country end products.



Regulatory Compliance

- ESD to the Electrical PINs: compatible with MIL-STD-883E Method 3015.4
- ESD to the LC Receptacle: compatible with IEC 61000-4-3
- EMI/EMC compatible with FCC Part 15 Subpart B Rules, EN55022:2010
- Laser Eye Safety compatible with FDA 21CFR, EN60950-1& EN (IEC) 60825-1,2
- RoHS compliant with EU RoHS 2.0 directive 2015/863/EU

Absolute Maximum Ratings

Parameter	Symbol	Min.	Typ.	Max.	Unit	Notes
Maximum Supply Voltage	Vcc	0		3.6	V	
Storage Temperature	TS	-40		+85	°C	
Operating Case Temperature	Tc	-40		+85	°C	
Relative Humidity	RH	5		85	%	1
Electrical static discharge (HBM Model)	ESD	500		1000	V	2
Receiver Optical Damage Threshold	RXDmg			+3.5	dBm	3

Notes:

1. Non-condensing
2. ESD, per JEDEC JESD22-A114-B
3. This must not be exceeded

Electrical Characteristics

Parameter	Symbol	Min.	Typ.	Max.	Unit	Notes
Power Supply Voltage	Vcc	3.14	3.3	3.46	V	
Power supply current	Icc			650	mA	
Total power dissipation	PD		1.5	2.0	W	

Optical Characteristics

Parameter	Symbol	Min.	Typ.	Max.	Unit
Transmitter					
Signaling Rate		1.0		11.3	Gbps
Optical Output Power	Po	-1		+3	dBm
Fiber Dispersion (SMF28 NDSF ITU-T G.652)		0		+700	ps/nm
Extinction Ratio (10.709 Gbps NRZ, Filtered)	ER	9.0	10.0		dB
Optical Eye Shape & Mask		GR-253 & ITU-T G.691/G.959.1 and IEEE 802.3 clause 52			
Eye Mask Margin		10			%
Spectral Width -20dB (10.709 Gbps NRZ)				0.3	nm
Optical Frequency Tuning Range (5 bands)		192.00 (1561.42)		195.90 (1530.33)	THz (nm)
Side-Mode Suppression Ratio	SMSR	30	35		dB
Optical Frequency Minimum Tuning Grid		100			GHz
Optical Centre Wavelength	λ_c	As per ITU-T 694.1			nm
Optical Frequency Accuracy (deviation from centre)		-2.5		+2.5	GHz
Time to Initialize Cooled Operation			10	90	Sec
Tuning Speed (Channel to Channel)				10	Sec
Receiver (Note 1)					
Receiver Wavelength Range		191.00 (1569.59)		197.00 (1521.79)	THz (nm)
Receiver Power		-27		-7	dBm
Receiver Optical Reflectance				-27	dB
LOS assert		-35		-30	dBm
LOS assert/de-assert hysteresis		0.5		2.0	dB
Data Rate (Gbps)	BER	Maximum Rx Sensitivity (dBm)			
			0km (Ops/nm)	40km (700ps/nm)	
1 – 10.7	$1 \cdot 10^{-12}$	-23		-19	
11.1 – 11.3	$1 \cdot 10^{-4}$	-27		-23	

Notes:

1. Measured with minimum ER; PRBS 2³¹-1; over specified wavelength range; OSNR >30 dB; with external clock and data recovery (CDR) board

OSNR Characteristics

Data Rate (Gbps)	BER	Dispersion (ps/nm)	RX Power Range (dBm)		OSNR (dB)	Notes
			Min	Max		
1 – 10.7	$1 \cdot 10^{-12}$	0	-18	-7	25	1
1 – 10.7	$1 \cdot 10^{-12}$	0 to 700 ps/nm	-18	-7	28	1
11.1 – 11.3	$1 \cdot 10^{-4}$	0	-18	-7	18	1
11.1 – 11.3	$1 \cdot 10^{-4}$	0 to 700 ps/nm	-18	-7	21	1

Notes:

1. Measured with fixed RxDTV; 0.55nm 3dB filter BW; OSNR resolution 0.2 nm; PRBS 2^31-1 ; with external clock and data recovery (CDR) board

Block Diagram

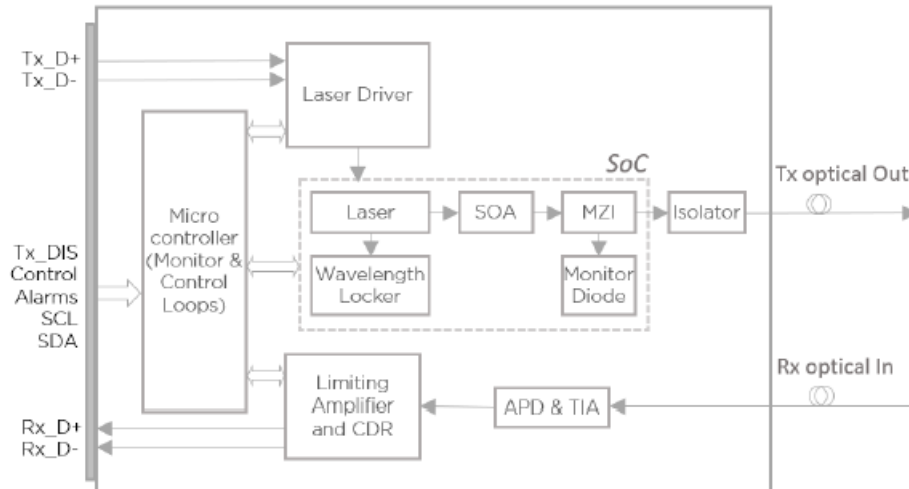

Electrical Pin-out Details

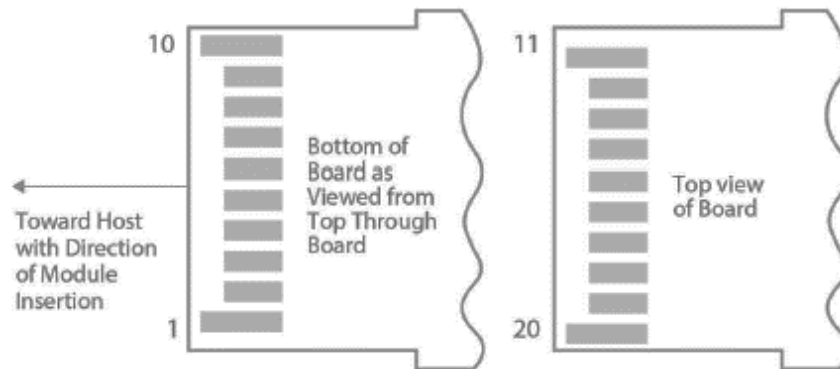

Pin Descriptions

Pin	Logic	Symbol	Name/Descriptions	Notes
1		VeeT	Module Transmitter Ground	1
2	LVTTTL-O	TX Fault	Module Transmitter Fault	2
3	LVTTTL-I	TX Disable	Transmitter Disable. Turns off laser output	3
4	LVTTTL-I/O	SDA	2-wire Serial interface Data line	
5	LVTTTL-I/O	SCL	2-wire Serial Interface Clock	
6		Mod ABS	Module absent, connect to VeeT or VeeR in the module	
7	LVTTTL-I	RS0	Unused	
8	LVTTTL-O	Rx LOS	Receiver Loss of Signal Indication	2
9	LVTTTL-I	RSI	Unused	
10		VeeR	Module Receiver Ground	1
11		VeeR	Module Receiver Ground	1
12	CML-O	RD-	Receiver Inverted Data Output	
13	CML-O	RD+	Receiver Non-Inverted Data Output	1
14		VeeR	Module Receiver Ground	
15		VccR	Module Receiver 3.3V Supply	
16		VccT	Module Transmitter 3.3V Supply	
17		VeeT	Module Transmitter Ground	1
18	CML-I	TD+	Transmitter Non-Inverted Data Input	
19	CML-I	TD-	Transmitter Inverted Data Input	
20		VeeT	Module Transmitter Ground	1

Notes:

1. The module signal ground pins, VeeR and VeeT, are isolated from the module chassis ground.
2. This pin is an open collector/drain output pin and shall be pulled up with 4.7-10 kohms to power supply voltage between 3.3V and 3.5V on the host board.
3. TX_Disable is an input contact with a 4.7-10 kohm pull-up to VccT inside the module.

Mechanical Specifications

Small Form Factor Pluggable (SFP+) transceivers are compatible with the dimensions defined by the SFP+ Multi-Sourcing Agreement (MSA).

W 13.9mm x L 56.5mm x H 11.85mm

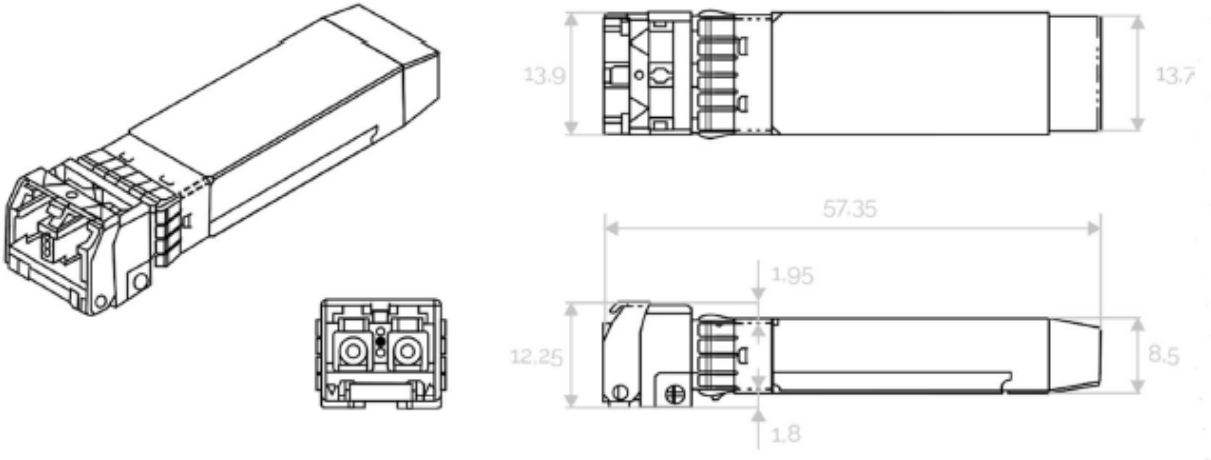

About Us:

Proline Options is one of North America's leading providers of transceivers and high speed cabling. With a reputation for quality, tested products that cover the connectivity spectrum, Proline Options has a solution for you regardless of the specification.

At Proline Options, every product is tested in its intended application - never batch or spec tested only. We run bandwidth, distance and IOS network tests. We have documented an impressive 0.03% failure rate over the last 10 years. To continue this rate of success we invest millions annually in our own on-site testing lab.



Tel: 855.933.3223

Email: sales@prolineoptions.com

Email: techsupport@prolineoptions.com

Web: <https://www.prolineoptions.com>