

### QSFP28-100GB-SR4-40M-PRO

Industry Standard Compatible TAA Compliant 100GBase-SR4 QSFP28 Transceiver (MMF, 850nm, 40m, DOM, 0 to 70C, MPO)

#### Features

- Compliant with IEEE Std 802.3bm, 100G BASE SR4 Ethernet
- Management interface specifications per SFF-8636
- Compliant with QSFP28 MSA
- 4 channels 850nm VCSEL array
- 4 channels PIN photo detector array
- Single MPO connector receptacle
- Class 1 laser safety certified
- Up to 103.1Gb/s data rates
- RoHS Compliant and Lead-Free
- Commercial Temperature: 0 to 70 Celsius



#### Applications:

- 100GBase Ethernet
- Access and Enterprise

#### Product Description

This MSA Compliant QSFP28 transceiver provides 100GBase-SR4 throughput up to 40m over OM4 multi-mode fiber (MMF) using a wavelength of 850nm via an MPO connector. It is built to MSA standards and is uniquely serialized and data-traffic and application tested to ensure that they will integrate into your network seamlessly. Digital optical monitoring (DOM) support is also present to allow access to real-time operating parameters. This transceiver is Trade Agreements Act (TAA) compliant. We stand behind the quality of our products and proudly offer a limited lifetime warranty.

Proline's transceivers are RoHS compliant and lead-free.

TAA refers to the Trade Agreements Act (19 U.S.C. & 2501-2581), which is intended to foster fair and open international trade. TAA requires that the U.S. Government may acquire only "U.S. – made or designated country end products.



## Absolute Maximum Ratings

Parameter	Symbol	Min.	Typ.	Max.	Unit	Notes
Power Supply Voltage	V <sub>CC</sub>	-0.5		4	V	
Storage Temperature	T <sub>stg</sub>	-40		85	°C	
Case Operating Temperature	T <sub>c</sub>	0	25	70	°C	
Relative Humidity	RH	5		95	%	
Data Rate	BR		25.78125		Gbps	
Transmission Distance	TD			40	m	1
Transmission Distance	TD			100	m	2

### Notes:

1. On OM4 MMF without host FEC. Or up to 30m on OM3 MMF without host FEC.
2. On OM4 MMF with host Clause 91 (RS) FEC. Or up to 70m on OM3 MMF with host Clause 91 (RS) FEC.

## Electrical Characteristics

Parameter	Symbol	Min.	Typ.	Max.	Unit	Notes
Power Supply Voltage	V <sub>CC</sub>	3.135	3.3	3.465	V	
Power Supply Current	I <sub>CC</sub>			750	mA	
Power Dissipation	P <sub>D</sub>			2.5	W	
<b>Transmitter</b>						
Input Differential Impedance	Z <sub>IN</sub>		100		Ω	
Differential Data Input Swing	V <sub>IN, P-P</sub>	180		900	mV <sub>P-P</sub>	
<b>Receiver</b>						
Output Differential Impedance	Z <sub>O</sub>		100		Ω	
Differential Data Output Swing	V <sub>OUT, P-P</sub>	300		850	mV <sub>P-P</sub>	1
Transition Time (20% to 80%)	T <sub>r, Tf</sub>	12			ps	

### Notes:

1. Internally AC coupled but requires an external 100Ω differential load termination.

## Optical Characteristics

Parameter	Symbol	Min.	Typ.	Max.	Unit	Notes
<b>Transmitter</b>						
Center Wavelength	$\lambda_C$	840	850	860	nm	
Optical Launch Power	Po	-4.5		+2.4	dBm	1
Transmit OMA per Lane	OMA	-4.5		+3	dBm	
Extinction Ratio	EX	2			dB	2
Spectral Width (RMS)	$\Delta\lambda$			0.6	nm	
TDEC per Lane	TDEC			4.3	dB	
Optical Return Loss Tolerance	ORLT			12	dB	
Eye Diagram	IEEE Std 802.3bm compatible					
<b>Receiver</b>						
Receiver Wavelength	$\lambda$	840	850	860	nm	
Average Receiver Sensitivity (Pavg)	S			-7	dBm	3
Receiver Overload (Pavg)	POL	2.4			dBm	
Damage Threshold	POL	3.4			dBm	
Optical Reflectance	ORL			-12	dB	
LOS De-Assert	LOSD			-11	dBm	
LOS Assert	LOSA	-30			dBm	
LOS Hysteresis		0.5		5	dB	

### Notes:

1. The optical power is launched into OM3 MMF.
2. Measured with a PRBS  $2^{31}-1$  test pattern @25.78125Gbps.
3. Measured with PRBS  $2^{31}-1$  test pattern, 25.78125Gb/s, BER<1E-12.

## Pin Descriptions

Pin	Logic	Symbol	Name/Descriptions	Ref.
1		GND	Transmitter Ground. (Common with Receiver Ground.)	1
2	CML-I	Tx2-	Transmitter Inverted Data Input.	
3	CML-I	Tx2+	Transmitter Non-Inverted Data Input.	
4		GND	Transmitter Ground. (Common with Receiver Ground.)	1
5	CML-I	Tx4-	Transmitter Inverted Data Input.	
6	CML-I	Tx4+	Transmitter Non-Inverted Data Input.	
7		GND	Transmitter Ground. (Common with Receiver Ground.)	1
8	LVTTTL-I	MODSEIL	Module Select.	2
9	LVTTTL-I	ResetL	Module Reset.	2
10		VccRx	+3.3V Receiver Power Supply.	
11	LVCNOS-I	SCL	2-Wire Serial Interface Clock.	2
12	LVCNOS-I/O	SDA	2-Wire Serial Interface Data.	2
13		GND	Transmitter Ground. (Common with Receiver Ground.)	1
14	CML-O	Rx3+	Receiver Non-Inverted Data Output.	
15	CML-O	Rx3-	Receiver Inverted Data Output.	
16		GND	Transmitter Ground. (Common with Receiver Ground.)	1
17	CML-O	Rx1+	Receiver Non-Inverted Data Output	
18	CML-O	Rx1-	Receiver Inverted Data Output.	
19		GND	Transmitter Ground. (Common with Receiver Ground.)	1
20		GND	Transmitter Ground. (Common with Receiver Ground.)	1
21	CML-O	Rx2-	Receiver Inverted Data Output.	
22	CML-O	Rx2+	Receiver Non-Inverted Data Output.	
23		GND	Transmitter Ground. (Common with Receiver Ground.)	1
24	CML-O	Rx4-	Receiver Inverted Data Output.	
25	CML-O	Rx4+	Receiver Non-Inverted Data Output.	
26		GND	Transmitter Ground. (Common with Receiver Ground.)	1
27	LVTTTL-O	ModPrsL	Module Present. Internally pulled down to GND.	
28	LVTTTL-O	IntL	Interrupt output should be pulled up on the host board.	2
29		VccTx	+3.3V Transmitter Power Supply.	
30		Vcc1	+3.3V Power Supply.	
31	LVTTTL-I	LPMODE	Low-Power Mode.	2
32		GND	Transmitter Ground. (Common with Receiver Ground.)	1
33	CML-I	Tx3+	Transmitter Non-Inverted Data Input.	
34	CML-I	Tx3-	Transmitter Inverted Data Input.	
35		GND	Transmitter Ground. (Common with Receiver Ground.)	1
36	CML-I	Tx1+	Transmitter Non-Inverted Data Input.	
37	CML-I	Tx1-	Transmitter Inverted Data Input.	
38		GND	Transmitter Ground. (Common with Receiver Ground.)	1

**Notes:**

1. The module signal grounds are isolated from the module case.
2. This is open collector/drain output that on the host board requires a 4.7KΩ to 10KΩ pull-up resistor to VccHost.

**Electrical Pin-Out Details**

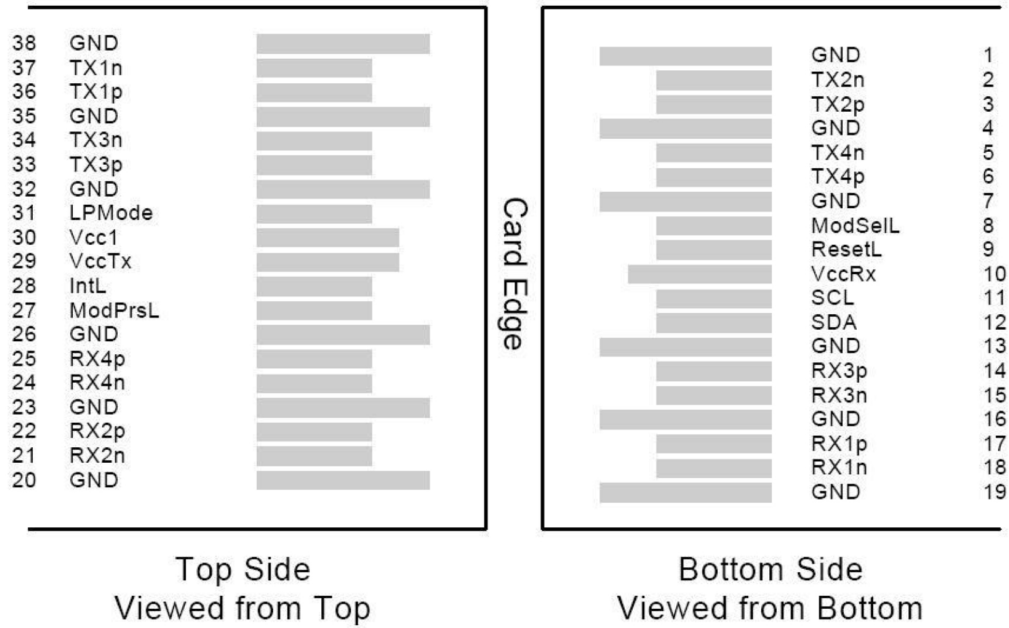

**Recommended Host Board Power Supply Filter Network**

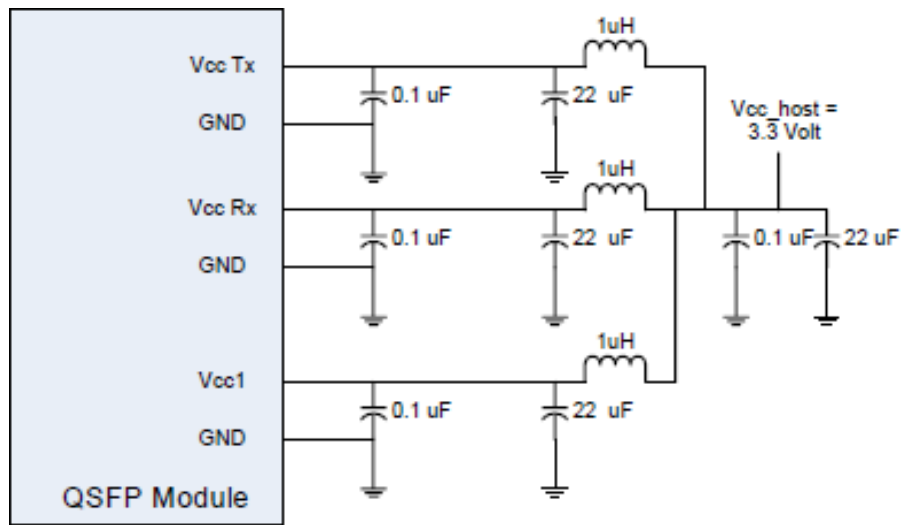

# Transceiver Interface Block Diagram

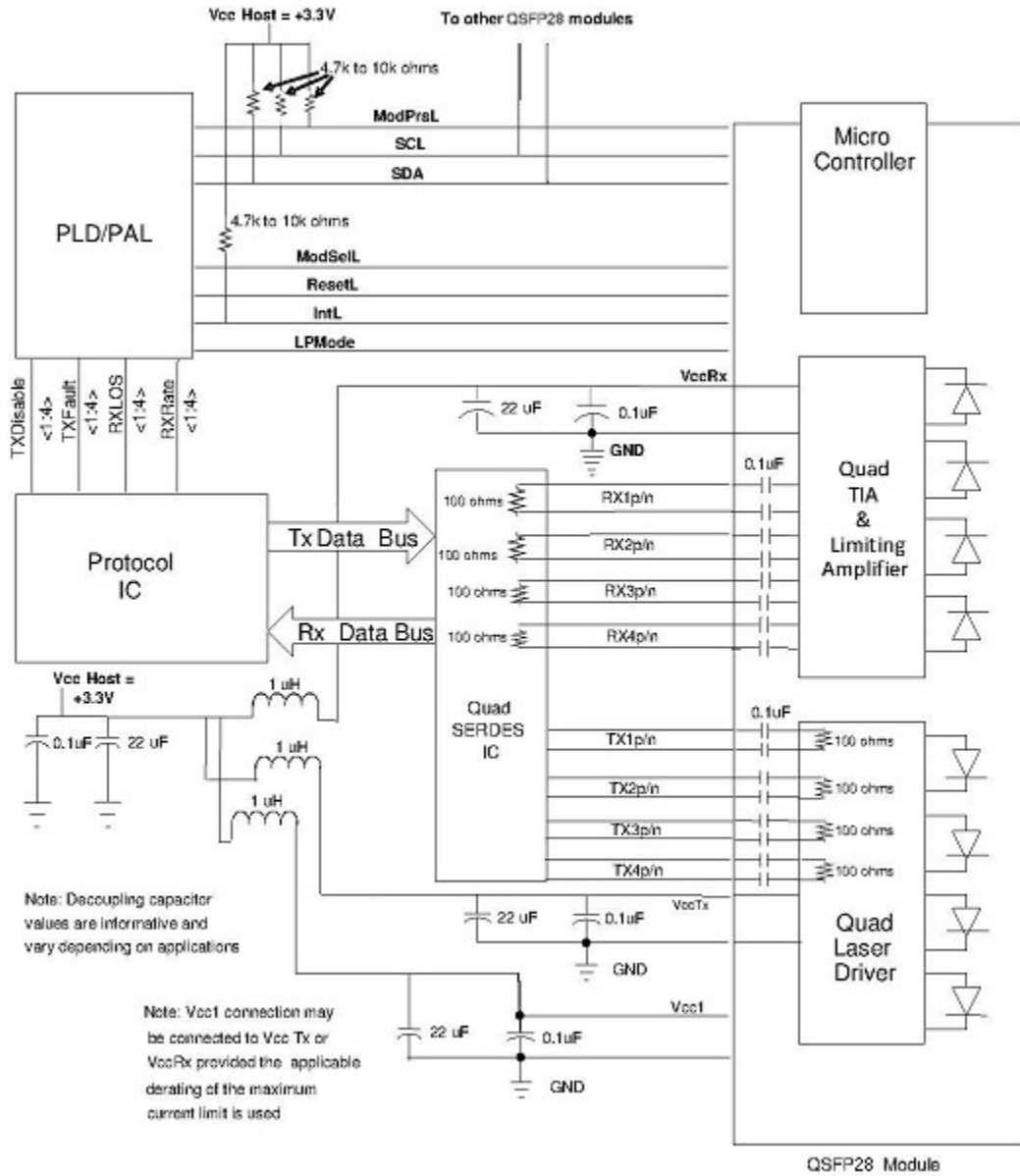

# Mechanical Specifications

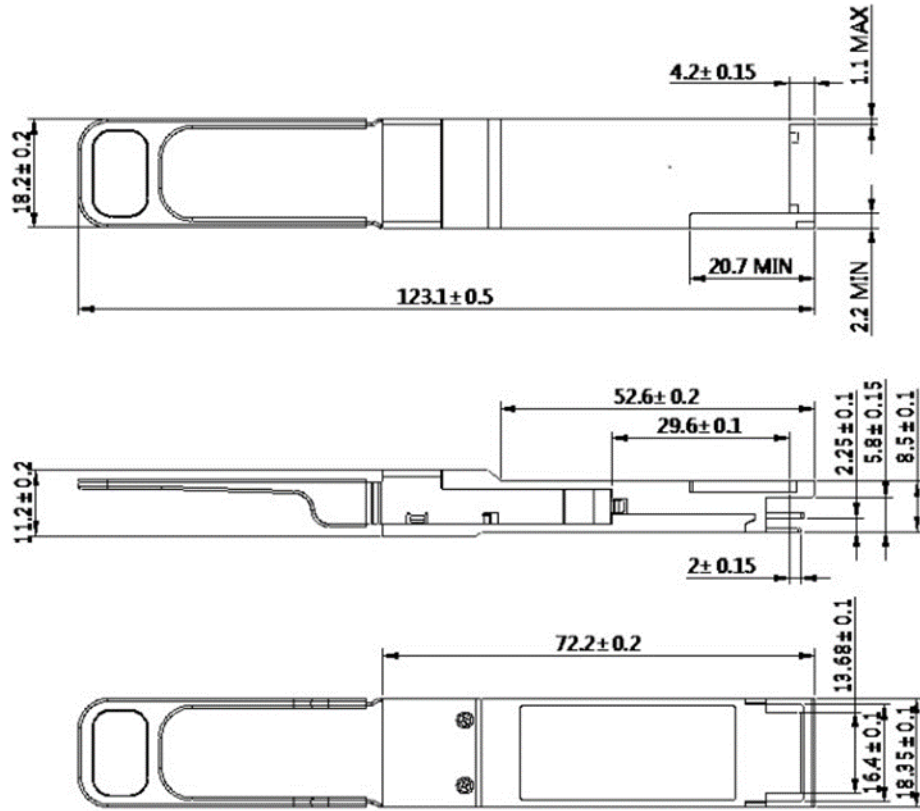

**About Us:**

Proline Options is one of North America's leading providers of transceivers and high speed cabling. With a reputation for quality, tested products that cover the connectivity spectrum, Proline Options has a solution for you regardless of the specification.

At Proline Options, every product is tested in its intended application - never batch or spec tested only. We run bandwidth, distance and IOS network tests. We have documented an impressive 0.03% failure rate over the last 10 years. To continue this rate of success we invest millions annually in our own on-site testing lab.



Tel: 855.933.3223

Email: [sales@prolineoptions.com](mailto:sales@prolineoptions.com)

Email: [techsupport@prolineoptions.com](mailto:techsupport@prolineoptions.com)

Web: <https://www.prolineoptions.com>