

## QSFP-40G-LR4-S-20-PRO

Cisco® QSFP-40G-LR4-S-20 Compatible TAA Compliant 40GBase-LR4 QSFP+ Transceiver (SMF, 1270nm to 1330nm, 20km, LC, DOM)

### Features:

- Compliant with IEEE Std 802.3ba, 40G Ethernet LR4
- Compliant with QSFP+MSA
- Management interface specifications per SFF-8436
- 4 CWDM Lane Mux/Demux design
- 4 channels CWDM DFB
- 4 channels PIN photo detector
- Up to 11.1 Gb/s per channel data links
- Single +3.3V power supply
- Class 1 laser safety certified
- Commercial operating temperature: 0°C to +70°C
- Up to 20km on SMF
- RoHS Compliant



### Applications:

- 40GBASE-LR4 40G Ethernet
- Fiber channel
- Data Center

### Product Description

This Cisco® QSFP-40G-LR4-S-20 compatible QSFP+ transceiver provides 40GBase-LR4 throughput up to 20km over single-mode fiber (SMF) using a wavelength of 1270nm to 1330nm via an LC connector. It is guaranteed to be 100% compatible with the equivalent Cisco® transceiver. This easy to install, hot swappable transceiver has been programmed, uniquely serialized and data-traffic and application tested to ensure that it will initialize and perform identically. Digital optical monitoring (DOM) support is also present to allow access to real-time operating parameters. This transceiver is Trade Agreements Act (TAA) compliant. We stand behind the quality of our products and proudly offer a limited lifetime warranty.

Proline's transceivers are RoHS compliant and lead-free.

TAA refers to the Trade Agreements Act (19 U.S.C. & 2501-2581), which is intended to foster fair and open international trade. TAA requires that the U.S. Government may acquire only "U.S. – made or designated country end products.



## Regulatory Compliance

- ESD to the Electrical PINs: compatible with MIL-STD-883E Method 3015.4
- ESD to the LC Receptacle: compatible with IEC 61000-4-3
- EMI/EMC compatible with FCC Part 15 Subpart B Rules, EN55022:2010
- Laser Eye Safety compatible with FDA 21CFR, EN60950-1& EN (IEC) 60825-1,2
- RoHS compliant with EU RoHS 2.0 directive 2015/863/EU

## Absolute Maximum Ratings

Parameter	Symbol	Min.	Typ.	Max.	Unit
Maximum Supply Voltage	Vcc	-0.5		4.0	V
Storage Temperature	TS	-40		+85	°C
Operating Case Temperature	Tc	0	25	70	°C
Relative Humidity	RH	5		95	%
Data Rate PER Channel			10.3125		Gb/s

## Electrical Characteristics

Parameter	Symbol	Min.	Typ.	Max.	Unit	Notes
Module Supply Current	Icc			1100	mA	
Power Dissipation	PD			3500	mW	
<b>Transmitter</b>						
Input Differential Impedance	Zin		100		Ω	
Differential Data Input Swing	VIN, P-P	180		900	mVp-p	
<b>Receiver</b>						
Output Differential Impedance				900	Ω	
Differential Data Output Swing	Zout, p-p	300		850	mVp-p	1
Data Output Rise Time, Fall Time	tr,tf	28			ps	2

## Notes:

1. Internally AC coupled, but requires an external 100Ω differential load termination.
2. 20-80%.

## Optical Characteristics

Parameter	Symbol	Min.	Typ.	Max.	Unit	Notes
<b>Transmitter</b>						
Launch Optical Power per lane	Po	-3		+2.3	dBm	1
Total Launch Optical Power	Po			+8	dBm	1
Center Wavelength	$\lambda_0$	1264.5	1271	1277.5	nm	
	$\lambda_1$	1284.5	1291	1297.5	nm	
	$\lambda_2$	1304.5	1311	1317.5	nm	
	$\lambda_3$	1324.5	1331	1337.5	nm	
Extinction Ratio	EX	3.5			dB	2
Spectral width (-20dB)	$\Delta\lambda$			1	nm	
Side Mode Suppression Ratio	SMSR	30			dB	
Transmitter and Dispersion Penalty	TDP			2.3	dB	
Optical Return Loss Tolerance	ORLT			12	dB	
Eye Diagram	IEEE Std 802.3ba compatible					
<b>Receiver</b>						
Center Wavelength	$\lambda_c$	1260		1340	nm	
Receiver Sensitivity (OMA)	S			-11.5	dBm	3
Damage Threshold	POL	3.3			dBm	3
Optical Return Loss	ORL	26			dB	
LOS De-Assert	LOSD			-12	dBm	
LOS Assert	LOSA	-30			dB	
LOS Hysteresis		0.5			dB	

### Notes:

1. The optical power is launched into SMF.
2. Measured with a PRBS  $2^{31}-1$  test pattern @ 10.3125 Gbps
3. Measured with a PRBS  $2^{31}-1$  test pattern, 10.3125 Gb/s, BER  $<10^{-12}$

## Pin Descriptions

Pin	Symbol	Name/Descriptions	Ref.
1	GND	Transmitter Ground (Common with Receiver Ground)	1
2	Tx2-	Transmitter Inverted Data Input	
3	Tx2+	Transmitter Non-Inverted Data output	
4	GND	Transmitter Ground (Common with Receiver Ground)	1
5	Tx4-	Transmitter Inverted Data Input	
6	Tx4+	Transmitter Non-Inverted Data output	
7	GND	Transmitter Ground (Common with Receiver Ground)	1
8	ModSelL	Module Select	2
9	ResetL	Module Reset	2
10	VccRx	3.3V Power Supply Receiver	
11	SCL	2-Wire serial Interface Clock	2
12	SDA	2-Wire serial Interface Data	2
13	GND	Transmitter Ground (Common with Receiver Ground)	1
14	Rx3+	Receiver Non-Inverted Data Output	
15	Rx3-	Receiver Inverted Data Output	
16	GND	Transmitter Ground (Common with Receiver Ground)	1
17	Rx1+	Receiver Non-Inverted Data Output	
18	Rx1-	Receiver Inverted Data Output	
19	GND	Transmitter Ground (Common with Receiver Ground)	1
20	GND	Transmitter Ground (Common with Receiver Ground)	1
21	Rx2-	Receiver Inverted Data Output	
22	Rx2+	Receiver Non-Inverted Data Output	
23	GND	Transmitter Ground (Common with Receiver Ground)	1
24	Rx4-	Receiver Inverted Data Output	1
25	Rx4+	Receiver Non-Inverted Data Output	
26	GND	Transmitter Ground (Common with Receiver Ground)	1
27	ModPrsl	Module Present	
28	IntL	Interrupt	2
29	VccTx	3.3V power supply transmitter	
30	Vcc1	3.3V power supply	
31	LPMODE	Low Power Mode	2
32	GND	Transmitter Ground (Common with Receiver Ground)	1
33	Tx3+	Transmitter Non-Inverted Data Input	
34	Tx3-	Transmitter Inverted Data Output	

35	GND	Transmitter Ground (Common with Receiver Ground)	1
36	Tx1+	Transmitter Non-Inverted Data Input	
37	Tx1-	Transmitter Inverted Data Output	
38	GND	Transmitter Ground (Common with Receiver Ground)	1

**Notes:**

1. The module signal grounds are isolated from the module case.
2. This is an open collector/drain output that on the host board requires a 4.7KΩ to 10KΩ pull-up resistor to Vcchost.

**Electrical Pin-out Details**

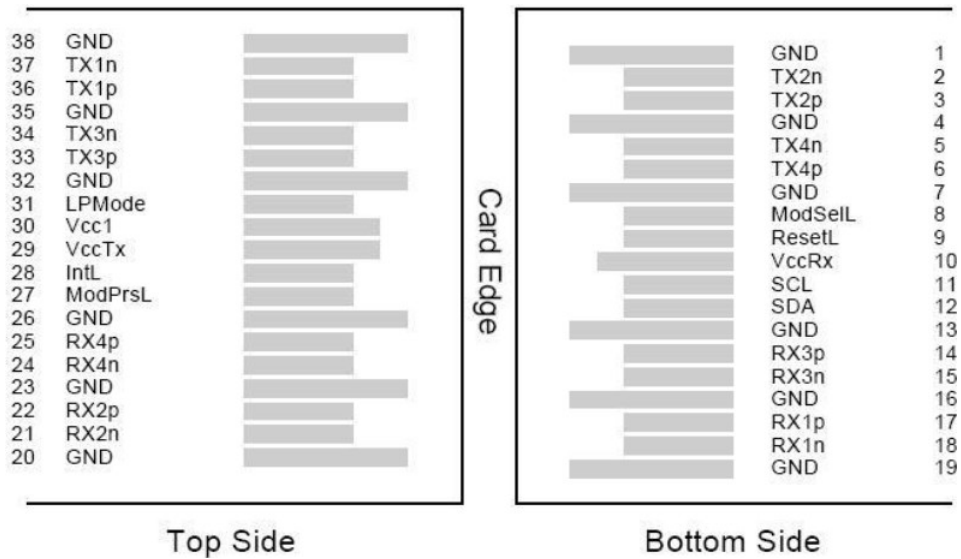

## Recommended Host Board Power Supply Filter Network

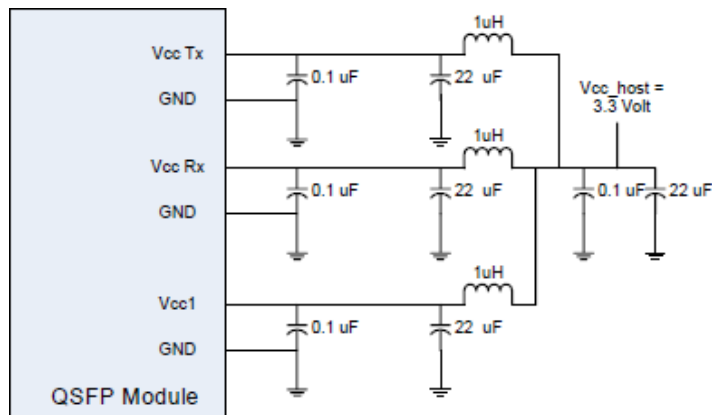

## Recommended Application Interface Block Diagram

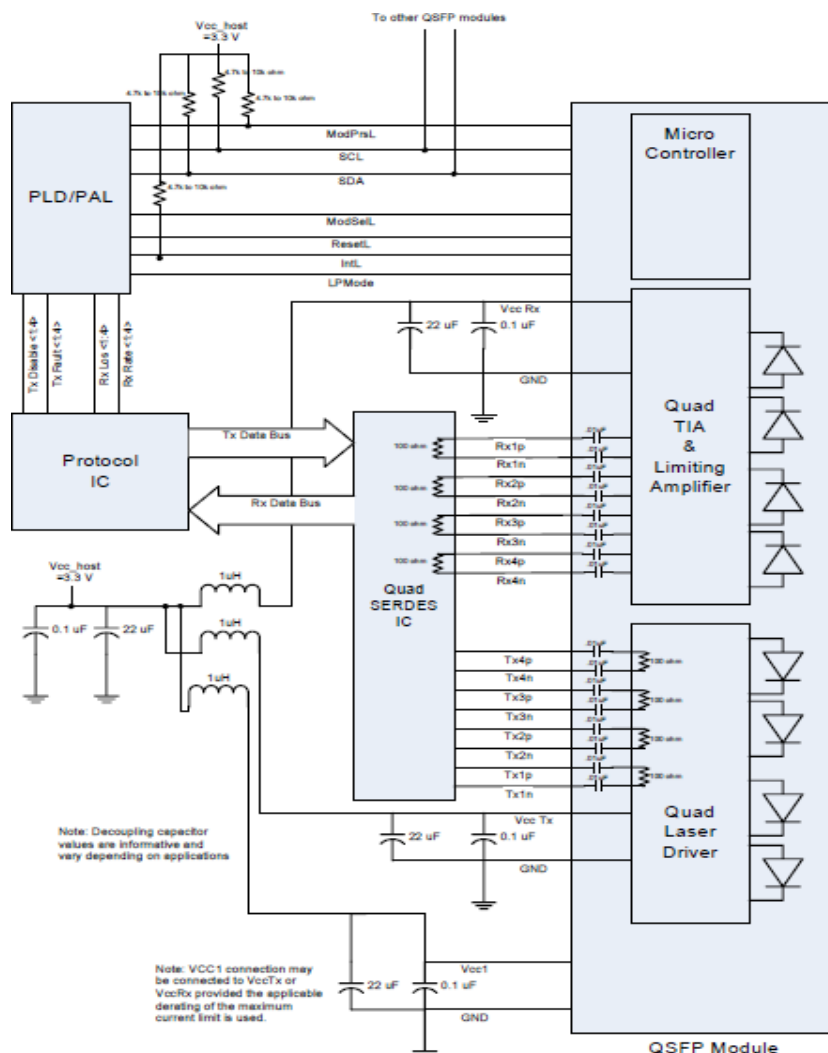

**Mechanical Specifications**

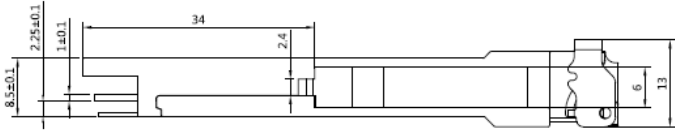
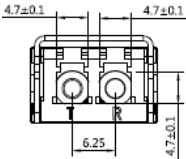
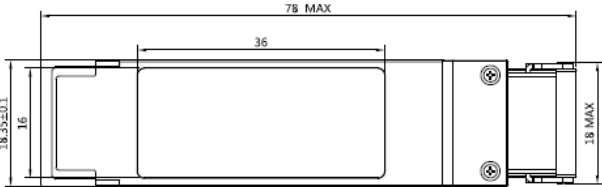

**Unit : mm**

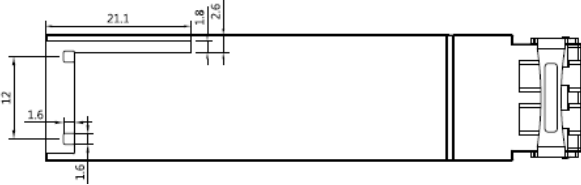

**About Us:**

Proline Options is one of North America's leading providers of transceivers and high speed cabling. With a reputation for quality, tested products that cover the connectivity spectrum, Proline Options has a solution for you regardless of the specification.

At Proline Options, every product is tested in its intended application - never batch or spec tested only. We run bandwidth, distance and IOS network tests. We have documented an impressive 0.03% failure rate over the last 10 years. To continue this rate of success we invest millions annually in our own on-site testing lab.

Tel: 855.933.3223

Email: [sales@prolineoptions.com](mailto:sales@prolineoptions.com)

Email: [techsupport@prolineoptions.com](mailto:techsupport@prolineoptions.com)

Web: <https://www.prolineoptions.com>