

QSFP-40G-ISM4-PRO

Huawei® QSFP-40G-ISM4 Compatible TAA Compliant 40GBase-PLR4 QSFP+ Transceiver (SMF, 1310nm, 1km, DOM, 0 to 70C, MPO)

Features

- SFF-8436 Compliance
- MPO Connector
- Commercial Temperature 0 to 70 Celsius
- Single-mode Fiber
- Hot Pluggable
- Excellent ESD Protection
- Metal with Lower EMI
- RoHS Compliant and Lead Free



Applications:

- 40GBase Ethernet
- Access and Enterprise

Product Description

This Huawei® QSFP-40G-ISM4 compatible QSFP+ transceiver provides 40GBase-PLR4 throughput up to 1km over single-mode fiber (SMF) using a wavelength of 1310nm via an MPO connector. It is guaranteed to be 100% compatible with the equivalent Huawei® transceiver. This easy to install, hot swappable transceiver has been programmed, uniquely serialized and data-traffic and application tested to ensure that it will initialize and perform identically. Digital optical monitoring (DOM) support is also present to allow access to real-time operating parameters. This transceiver is Trade Agreements Act (TAA) compliant. We stand behind the quality of our products and proudly offer a limited lifetime warranty.

Proline's transceivers are RoHS compliant and lead-free.

TAA refers to the Trade Agreements Act (19 U.S.C. & 2501-2581), which is intended to foster fair and open international trade. TAA requires that the U.S. Government may acquire only "U.S. – made or designated country end products.



Absolute Maximum Ratings

Parameter	Symbol	Min.	Typ.	Max.	Unit
Supply Voltage	V _{CC}	0		+3.6	V
Storage Temperature	T _{st}	-40		+85	°C
Humidity (non-condensing)	Rh	5		85	%

Recommended Operating Conditions

Parameter	Symbol	Min.	Typ.	Max.	Unit
Power Supply Voltage	V _{CC}	3.13	3.3	3.47	V
Operating Case Temperature	T _{ca}	0	25	+70	°C
Data Rate Per Channel				10.3125	Gbps
Power Supply Voltage	V _{CC}	3.135	3.3	3.465	%
Power Supply Current				2.5	W

Electrical Characteristics

Parameter	Symbol	Min.	Typ.	Max.	Unit	Notes
Transmitter Differential Input Voltage	V _{IN}	180		800	mV _{pp}	
Receiver Differential Output Voltage	V _O	400	450	850	mV _{pp}	1
Loss of Signal (LOS)	V _{CH}	2		V _{CC}	V	2
	V _{OL}	V _{EE}		V _{EE} + 0.8		
Transmitter Disable (TX-Disable)	V _{IH}	2		V _{CC}	V	
	V _{IL}	V _{EE}		V _{EE} + 0.8		
Rx Output Rise and Fall Time	T _r /T _f	28			P _s	20% to 80%

Notes:

1. SFF-8431, SFP+ Module receiver output specifications at C'.
2. LOS is an open collector output. Should be pulled up with 4.7kΩ – 10kΩ on the host board. Normal operation is logic 0; loss of signal is logic 1.

Optical Characteristics

Parameter	Symbol	Unit	Min.	Typ.	Max.	Notes
Transmitter						
Average Launch Power, each lane	P _o	dBm	-8.2		+0.5	
Center wavelength	λ _c	nm	1260		1355	
Optical Spectral Width (RMS)	Δλ	nm			2.5	
Extinction ratio	ER	Db	3.0			
Optical power OMA, each lane	P _{OMA}	dBm	-5.2		+1.5	1
Average launch power of OFF transmitted, each lane	P _{off}	dBm			-30	
RIN ₁₂ OMA	RIN	dB/Hz			-128	
Optical return loss tolerance	ORL _T	dB	12			2
Output eye		Compliant with IEEE802.3ba eye mask				
Receiver						
Center Wavelength	λ _c	nm	1260		1355	
Receiver Overload in OMA, each lane	RxOMA	dBm	+1.5			
Receiver Overload in average power, each lane	P _{max}	dBm	+0.5			3
Average receive power, each lane	RxP _x	dBm	-11.5			4
Receiver Sensitivity in OMA, each lane	Se _{nOMA}	dBm			-9.5	5, for 1.0km type
Receiver Sensitivity in OMA, each lane	Se _{nOMA}	dBm			-10.5	5, for 1.5km type
Receiver Crossing	RCP	%	45		55	
Receiver Eye Mask	SFF-8431, SFP+MODULE RECEIVER OUTPUT SPECIFICATIONS AT 'C'.					
Receiver Eye Mask Margin	REMM	%	0			
Receiver Reflectance	R _{rx}	dB			-12	
LOS	Assert	LOSA	dBm	-30		
	De-assert	LOSD	dBm		-12	
LOS Hysteresis	LOSH	dB	0.5		6	

Notes:

1. Even if the TDP < 1 dB, the OMA (min) must exceed this value.
2. Transmitter reflectance is defined looking into the transmitter
3. The receiver shall be able to tolerate, without damage, continuous exposure to an optical input signal having a power level equal to the average receive power (max) plus at least 1 dB.
4. Average receive power (min) is informative and not the principal indicator of signal strength. A received power below this value cannot be compliant; however, a value above this does not ensure compliance.
5. PRBS 231 -1 at BER 10⁻¹², ER=3.0dB

Digital Diagnostic Memory Map

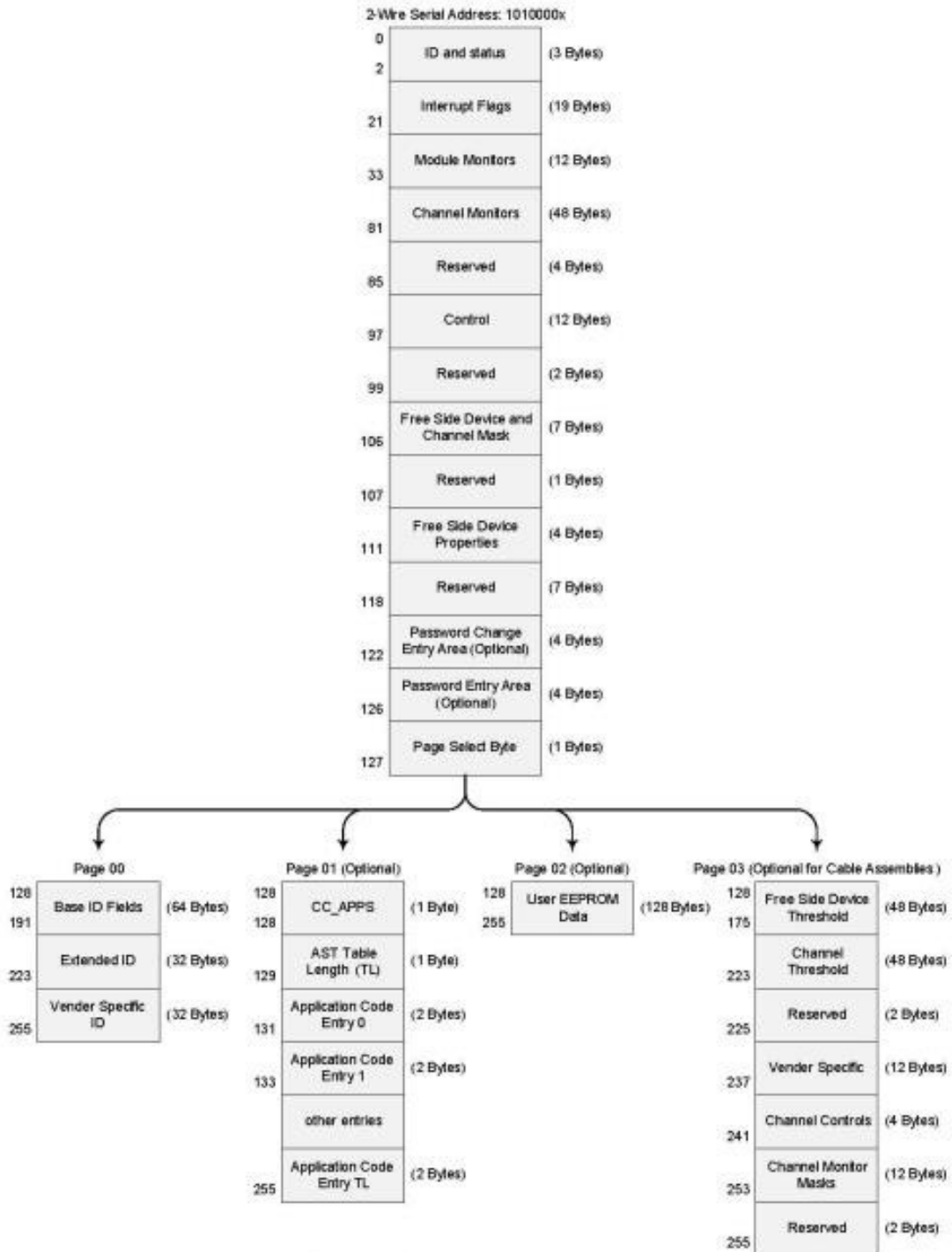

Pin Descriptions

Pin	Logic	Symbol	Name/Descriptions	Ref.
1		GND	Module Ground	1
2	CML-I	Tx2-	Transmitter inverted data input	
3	CML-I	Tx2+	Transmitter non-inverted data input	
4		GND	Module Ground	1
5	CML-I	Tx4-	Transmitter inverted data input	
6	CML-I	Tx4+	Transmitter non-inverted data input	
7		GND	Module Ground	1
8	LVTTL-I	MODSEIL	Module Select	2
9	LVTTL-I	ResetL	Module Reset	2
10		VCCRx	+3.3v Receiver Power Supply	
11	LVC MOS-I	SCL	2-wire Serial interface clock	2
12	LVC MOS-I/O	SDA	2-wire Serial interface data	2
13		GND	Module Ground	1
14	CML-O	RX3+	Receiver non-inverted data output	
15	CML-O	RX3-	Receiver inverted data output	
16		GND	Module Ground	1
17	CML-O	RX1+	Receiver non-inverted data output	
18	CML-O	RX1-	Receiver inverted data output	
19		GND	Module Ground	1
20		GND	Module Ground	1
21	CML-O	RX2-	Receiver inverted data output	
22	CML-O	RX2+	Receiver non-inverted data output	
23		GND	Module Ground	1
24	CML-O	RX4-	Receiver inverted data output	
25	CML-O	RX4+	Receiver non-inverted data output	
26		GND	Module Ground	1
27	LVTTL-O	ModPrsL	Module Present, internal pulled down to GND	
28	LVTTL-O	IntL	Interrupt output should be pulled up on host board	2
29		VCCTx	+3.3v Transmitter Power Supply	
30		VCC1	+3.3v Power Supply	
31	LVTTL-I	LPMODE	Low Power Mode	2
32		GND	Module Ground	1
33	CML-I	Tx3+	Transmitter non-inverted data input	
34	CML-I	Tx3-	Transmitter inverted data input	
35		GND	Module Ground	1
36	CML-I	Tx1+	Transmitter non-inverted data input	
37	CML-I	Tx1-	Transmitter inverted data input	
38		GND	Module Ground	1

Notes:

1. GND is the symbol for signal and supply (power) common for QSFP+ modules. All are common within the QSFP+ module and all module voltages are referenced to this potential unless otherwise noted. Connect these directly to the host board signal common ground plane.
2. VccRx, Vcc1 and VccTx are the receiver and transmitter power suppliers and shall be applied concurrently. Recommended host board power supply filtering is shown in the figure below. Vcc Rx, Vcc1 and VccTx may be internally connected within the QSFP+ transceiver module in any combination. The connector pins are each rated for a maximum current of 500mA.

Electrical Pin-out Details

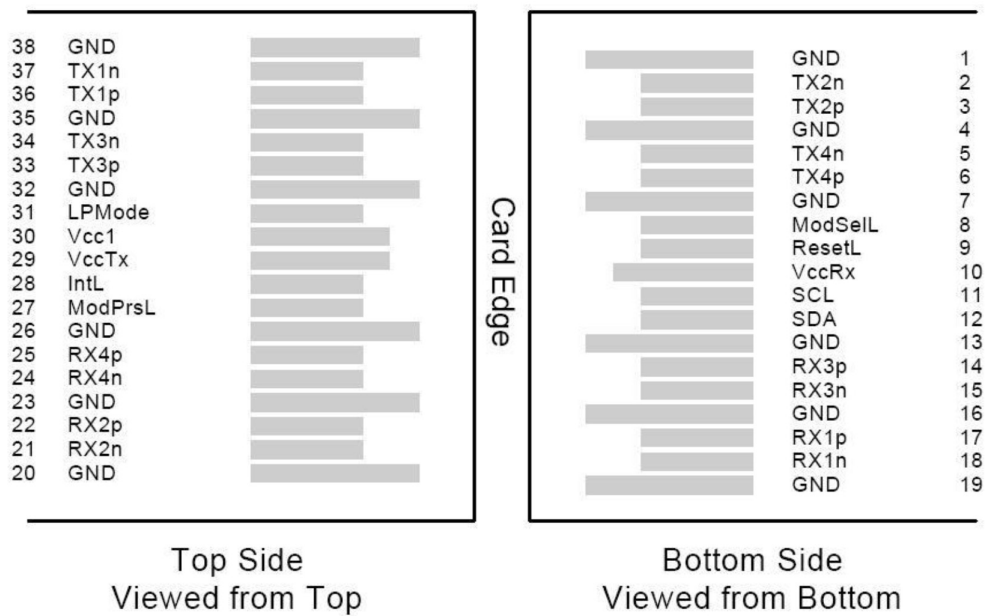

Recommended Power Supply Filter

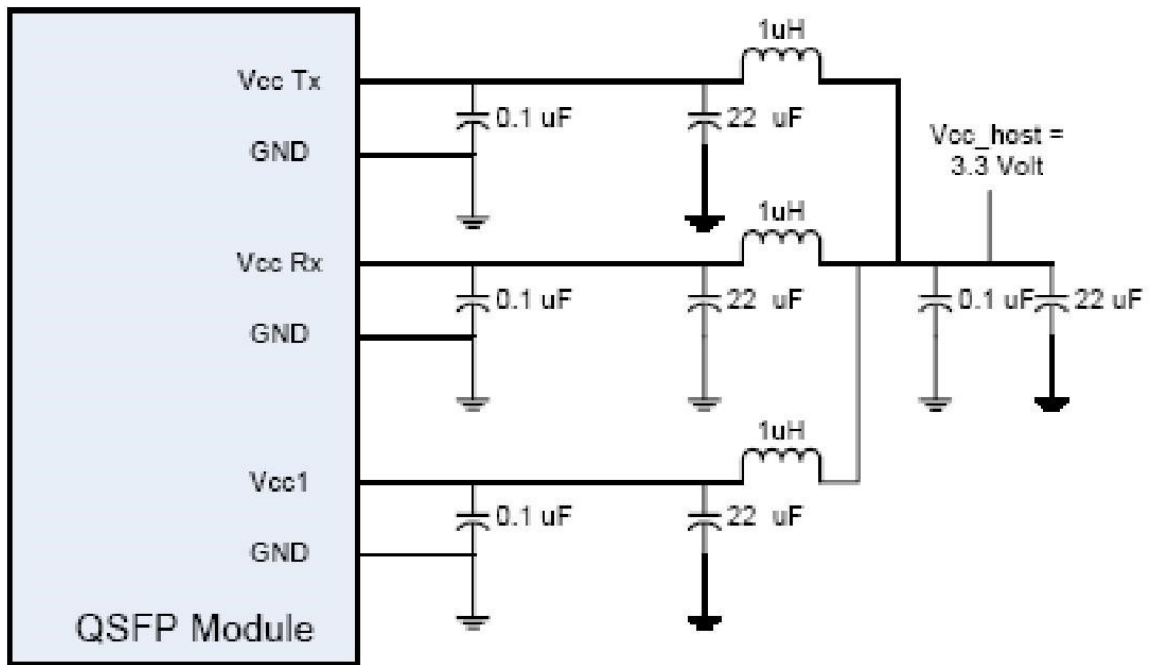

Typical Application Circuit

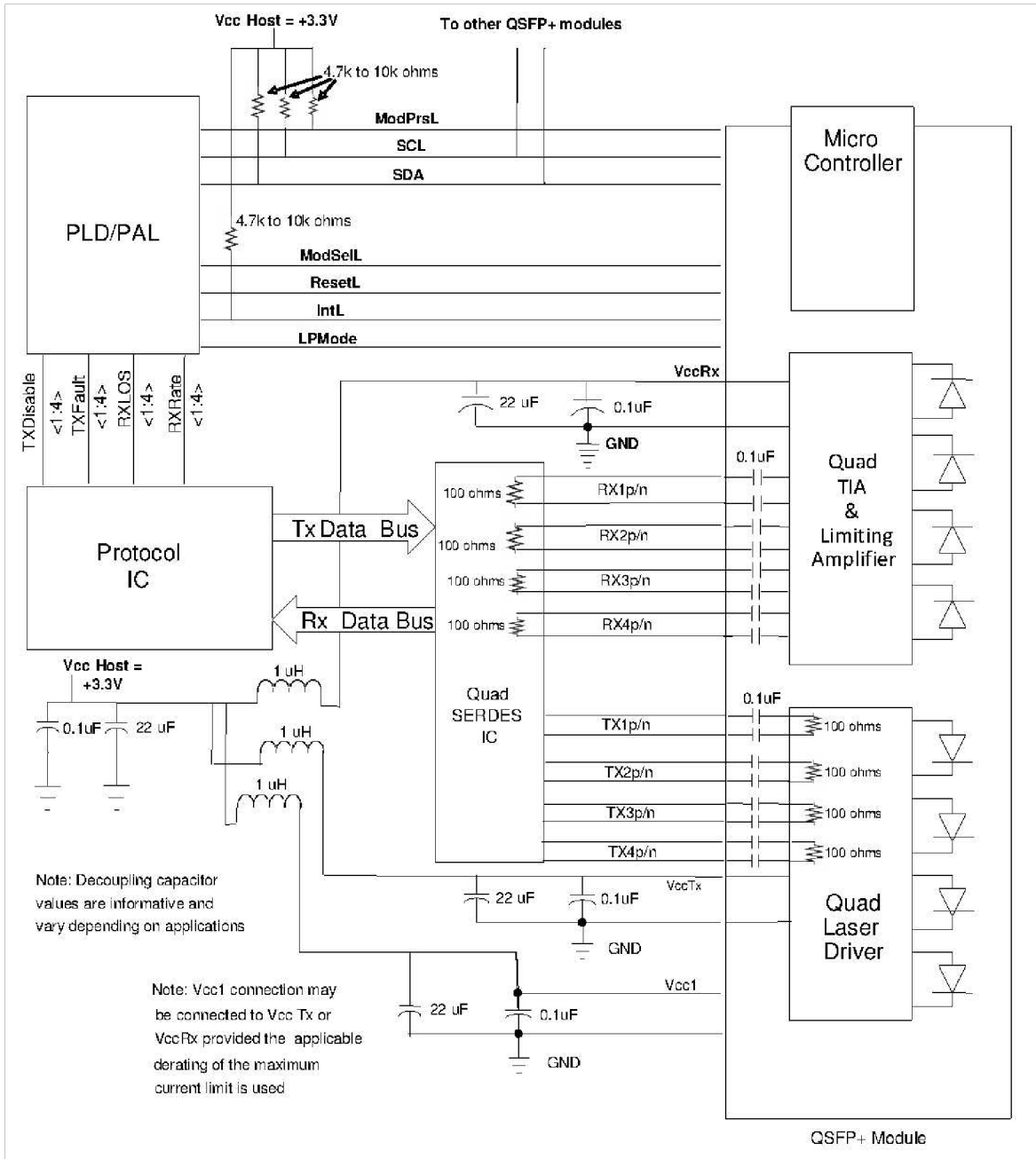

Mechanical Specifications

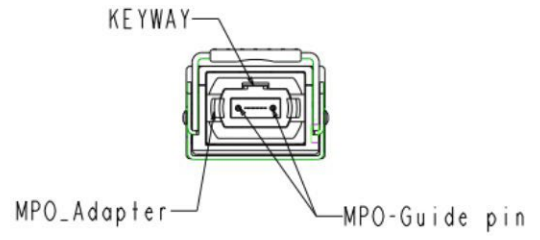
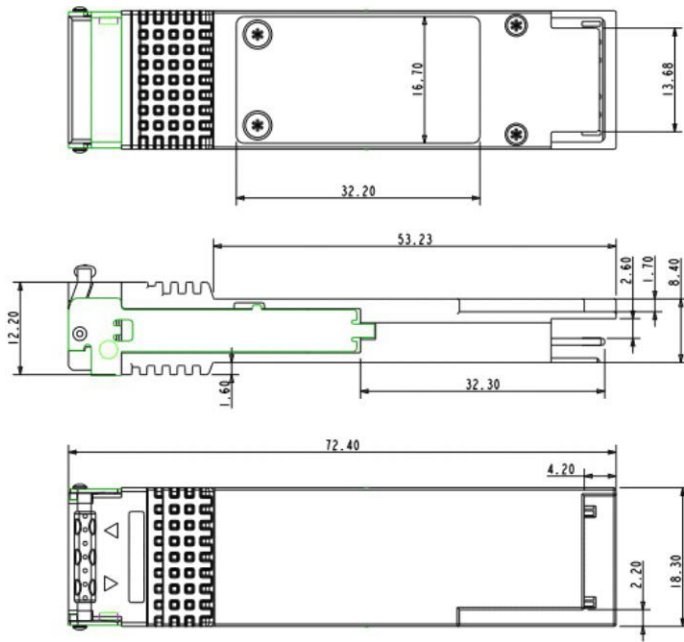

About Us:

Proline Options is one of North America's leading providers of transceivers and high speed cabling. With a reputation for quality, tested products that cover the connectivity spectrum, Proline Options has a solution for you regardless of the specification.

At Proline Options, every product is tested in its intended application - never batch or spec tested only. We run bandwidth, distance and IOS network tests. We have documented an impressive 0.03% failure rate over the last 10 years. To continue this rate of success we invest millions annually in our own on-site testing lab.



Tel: 855.933.3223

Email: sales@prolineoptions.com

Email: techsupport@prolineoptions.com

Web: <https://www.prolineoptions.com>