

QDD-400G-XDR4-PRO

Juniper Networks® QDD-400G-XDR4 Compatible TAA Compliant 400GBase-DR4 QSFP-DD Transceiver (SMF, 1310nm, 2km, DOM, 0 to 70C, MPO)

Features

- INF-8628 Compliance
- MPO Connector
- Commercial Temperature 0 to 70 Celsius
- Single-mode Fiber
- Hot Pluggable
- Excellent ESD Protection
- Metal with Lower EMI
- RoHS Compliant and Lead Free



Applications:

- 400GBase Ethernet
- Access, Metro and Enterprise

Product Description

This Juniper Networks® QDD-400G-XDR4 compatible QSFP-DD transceiver provides 400GBase-DR4 throughput up to 2km over single-mode fiber (SMF) using a wavelength of 1310nm via an MPO connector. It is guaranteed to be 100% compatible with the equivalent Juniper Networks® transceiver. This easy to install, hot swappable transceiver has been programmed, uniquely serialized and data-traffic and application tested to ensure that it will initialize and perform identically. Digital optical monitoring (DOM) support is also present to allow access to real-time operating parameters. This transceiver is Trade Agreements Act (TAA) compliant. We stand behind the quality of our products and proudly offer a limited lifetime warranty.

Proline's transceivers are RoHS compliant and lead-free.

TAA refers to the Trade Agreements Act (19 U.S.C. & 2501-2581), which is intended to foster fair and open international trade. TAA requires that the U.S. Government may acquire only "U.S. – made or designated country end products.



Absolute Maximum Ratings

Parameter	Symbol	Min.	Max.	Unit
Maximum Power Supply Voltage	VCC	-0.5	3.6	V
Storage Temperature	Ts	-40	85	°C
Case Operating Temperature	Top	0	70	°C
Relative Humidity	RH	15	85	%
Receiver Damage Threshold per lane	PRdmg	5		dBm

Optical Characteristics

Parameter	Symbol	Min.	Typ.	Max.	Unit	Notes
Transmitter						
PAM4 Signaling rate		53.125 ± 100 ppm			GBaud	
Lane wavelength (range)		1304.5	1311	1317.5	nm	
Side Mode Suppression Ratio	SMSR	30			dB	
Total average launch power				9.3	dBm	
Average launch power		-3.3		3.5	dBm	1
Outer Optical Modulation Amplitude	OMAouter	-0.3		3.7	dBm	2
Difference in launch power between any two lanes (OMAouter)				4	dB	
Launch power in OMAouter minus TDECQ, for ER≥4.5dB	OMAouter-TDECQ	-1.7			dBm	
Launch power in OMAouter minus TDECQ, for ER < 4.5dB	OMAouter-TDECQ	-1.6			dBm	
Transmitter and dispersion penalty Eye Closure for PAM4	TDECQ			3.4	dB	
TDECQ – 10*log10(Ceq), each lane				3.4	dB	3
Extinction Ratio	ER	3.5			dB	
Average Launch Power of OFF Transmitter per lane				-20	dBm	
Transmitter transition time				17	ps	
RIN17.1 OMA	RIN			-136	dB/Hz	
Optical Return Loss Tolerance				17.1	dB	
Transmitter Reflectance				-26	dB	4
Receiver						
PAM4 Signaling rate (range)		53.125 ± 100 ppm			GBaud	
Lane wavelength (range)		1304.5	1311	1317.5	nm	
Damage Threshold		5			dBm	5
Average Receive Power		-7.3		3.5	dBm	6
Receive Power (OMAouter)	RxOMAouter			3.7	dBm	
Difference in receive power between any two lanes (OMAouter)				4.1	dB	
Receiver reflectance				-26	dB	
Receiver sensitivity (OMAouter)		max(-4.6,SSSSSSSS-6.0)			dBm	7
Stressed Receiver Sensitivity (OMAouter)				-2.6	dBm	8
Stressed Conditions for Stress Receiver Sensitivity						
Stressed eye closure for PAM4 (SECQ), lane under test				3.4	dB	
SECQ – 10*log10 (Ceq), lane under test (max)				3.4	dB	9
OMAouter of each aggressor lane		1.5			dBm	
LOS Assert		-30		-7.5	dBm	
LOS De-Assert		-29.5		-7.0	dBm	
LOS Hysteresis		0.5			dB	

Notes:

1. Average launch power, (min) is informative and not the principal indicator of signal strength. A transmitter with launch power below this value cannot be compliant; however, a value above this does not ensure compliance.
2. Even if the TDECQ < 1.4 dB for an extinction ratio of ≥ 4.5 dB or TDECQ < 1.3 dB for an extinction ratio of < 4.5dB, the OMA_{outer} (min) must exceed this value
3. Ceq is a coefficient defined in IEEE Std 802.3-2018 clause 121.8.5.3 which accounts for reference equalizer noise enhancement.
4. Transmitter reflectance is to look into the transmitter.
5. The receiver shall be able to tolerate, without damage, continuous exposure to an optical signal having this average power level. The receiver does not have to operate correctly at this input power.
6. Average receive power, (min) is informative and not the principal indicator of signal strength. A received power below this value cannot be compliant; however, a value above this does not ensure compliance.
7. Receiver sensitivity is informative and is defined for a transmitter with a value of SECQ up to 3.4 dB. Receiver sensitivity should meet Equation: $RRSS = \max(-4.6, SSSSSSS - 6.0) dddddd$,

Where:

RS is the receiver sensitivity, and

SECQ is the SECQ of the transmitter used to measure the receiver sensitivity. The normative requirement for receivers is stressed receiver sensitivity.

8. Measured with conformance test signal at TP3 for BER specified in IEEE Std 802.3-2018 clause 124.1.1
9. Ceq is a coefficient defined in IEEE Std 802.3-2018 clause 121.8.5.3 which accounts for reference equalizer noise enhancement.

Pin Descriptions

Pin	Logic	Symbol	Name/Descriptions	Plug Sequence
1		GND	Ground	1B
2	CML-I	Tx2n	Transmitter Inverted Data Input	3B
3	CML-I	Tx2p	Transmitter Non-Inverted Data Input	3B
4		GND	Ground	1B
5	CML-I	Tx4n	Transmitter Inverted Data Input	3B
6	CML-I	Tx4p	Transmitter Non-Inverted Data Input	3B
7		GND	Ground	1B
8	LVTTL-I	ModSelL	Module Select	3B
9	LVTTL-I	ResetL	Module Reset	3B
10		VccRx	+3.3V Power Supply Receiver	2B
11	LVCNOS-I/O	SCL	2-wire serial interface clock	3B
12	LVCNOS-I/O	SDA	2-wire serial interface data	3B
13		GND	Ground	1B
14	CML-O	Rx3p	Receiver Non-Inverted Data Output	3B
15	CML-O	Rx3n	Receiver Inverted Data Output	3B
16	GND	Ground	1B	
17	CML-O	Rx1p	Receiver Non-Inverted Data Output	3B
18	CML-O	Rx1n	Receiver Inverted Data Output	3B
19		GND	Ground	1B
20		GND	Ground	1B
21	CML-O	Rx2n	Receiver Inverted Data Output	3B
22	CML-O	Rx2p	Receiver Non-Inverted Data Output	3B
23		GND	Ground	1B
24	CML-O	Rx4n	Receiver Inverted Data Output	3B
25	CML-O	Rx4p	Receiver Non-Inverted Data Output	3B
26		GND	Ground	1B
27	LVTTL-O	ModPrsL	Module Present	3B
28	LVTTL-O	IntL	Interrupt	3B
29		VccTx	+3.3V Power supply transmitter	2B
30		Vcc1	+3.3V Power supply	2B
31	LVTTL-I	InitMode	Initialization mode; In legacy QSFP applications, the InitMode pad is called LPMODE	3B
32		GND	Ground	1B
33	CML-I	Tx3p	Transmitter Non-Inverted Data Input	3B
34	CML-I	Tx3n	Transmitter Inverted Data Input	3B
35		GND	Ground	1B
36	CML-I	Tx1p	Transmitter Non-Inverted Data Input	3B
37	CML-I	Tx1n	Transmitter Inverted Data Input	3B
38		GND	Ground	1B
39		GND	Ground	1A
40	CML-I	Tx6n	Transmitter Inverted Data Input	3A

41	CML-I	Tx6p	Transmitter Non-Inverted Data Input	3A
42		GND	Ground	1A
43	CML-I	Tx8n	Transmitter Inverted Data Input	3A
44	CML-I	Tx8p	Transmitter Non-Inverted Data Input	3A
45		GND	Ground	1A
46		Reserved	For future use	3A
47		VS1	Module Vendor Specific 1	3A
48		VccRx1	3.3V Power Supply	2A
49		VS2	Module Vendor Specific 2	3A
50		VS3	Module Vendor Specific 3	3A
51		GND	Ground	1A
52	CML-O	Rx7p	Receiver Non-Inverted Data Output	3A
53	CML-O	Rx7n	Receiver Inverted Data Output	3A
54		GND	Ground	1A
55	CML-O	Rx5p	Receiver Non-Inverted Data Output	3A
56	CML-O	Rx5n	Receiver Inverted Data Output	3A
57		GND	Ground	1A
58		GND	Ground	1A
59	CML-O	Rx6n	Receiver Inverted Data Output	3A
60	CML-O	Rx6p	Receiver Non-Inverted Data Output	3A
61		GND	Ground	1A
62	CML-O	Rx8n	Receiver Inverted Data Output	3A
63	CML-O	Rx8p	Receiver Non-Inverted Data Output	3A
67		GND	Ground	1A
68		NC	No Connect	3A
69		Reserved	For future use	3A
70		VccTx1	3.3V Power Supply	2A
71		Vcc2	3.3V Power Supply	2A
72		Reserved	For Future Use	3A
73		GND	Ground	1A
74	CML-I	Tx7p	Transmitter Non-Inverted Data Input	3A
75	CML-I	Tx7n	Transmitter Inverted Data Input	3A
76		GND	Ground	1A

QSFPDD Connector Pin Definition

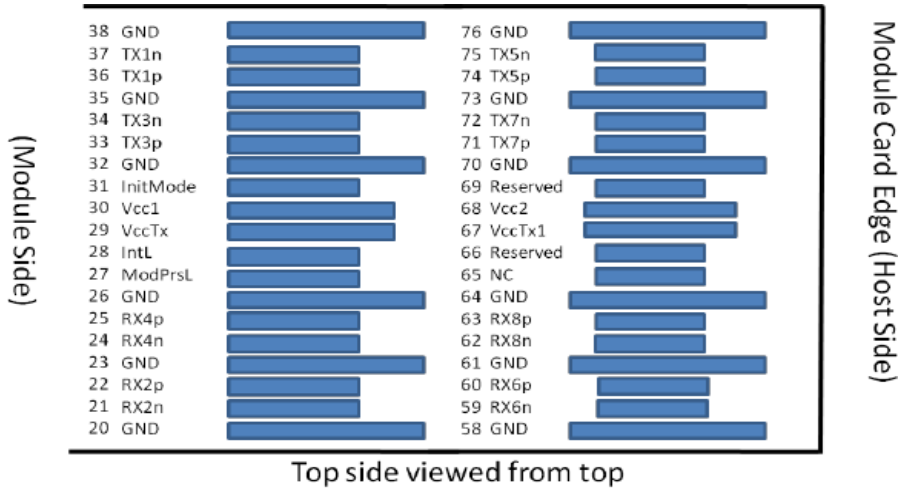

Legacy QSFP28 Pads

Additional QSFP-DD Pads

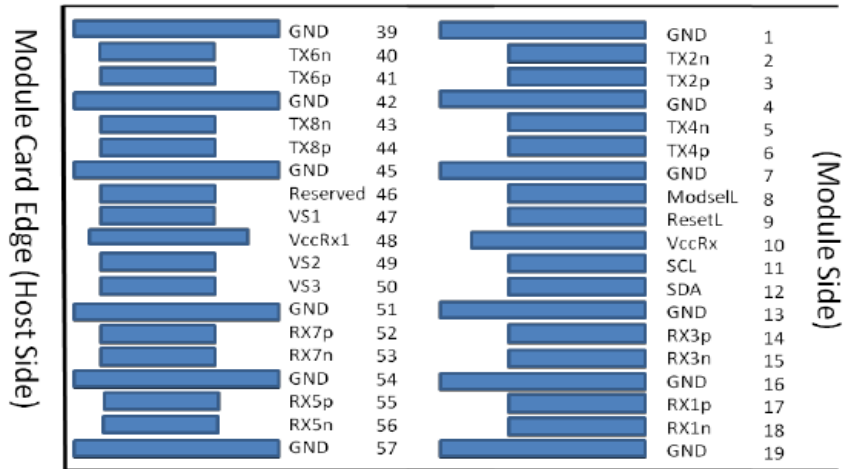

Additional QSFP-DD Pads

Legacy QSFP28 Pads

Recommended Power Supply Filter

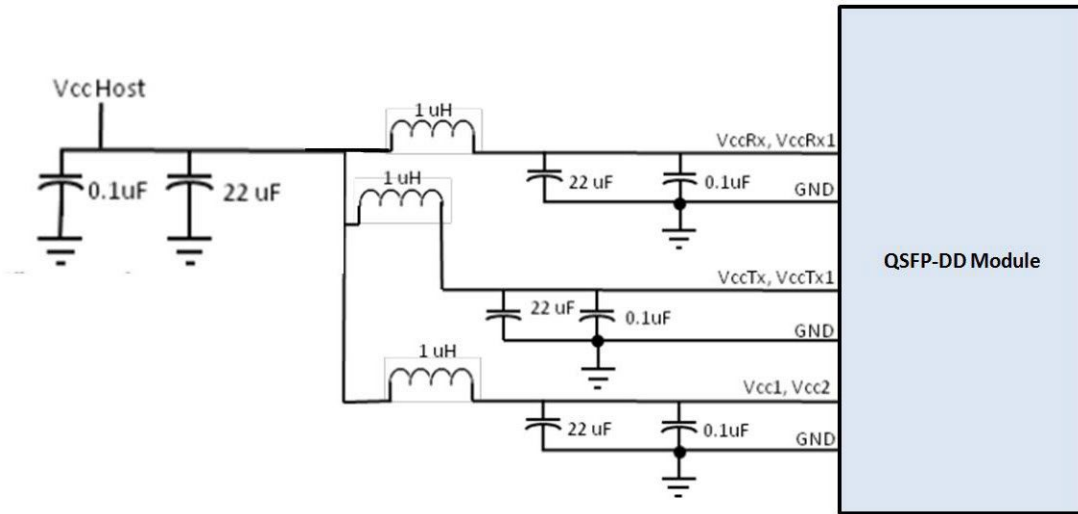

Digital Diagnostic Functions

The following digital diagnostic characteristics are defined over the normal operating conditions unless otherwise specified.

Parameter	Symbol	Min	Max	Units	Notes
Temperature monitor	DMI_Temp	-3	3	degC	0-70 degC
Supply voltage monitor	DMI_VCC	-0.1	0.1	V	Over full operating range
Channel RX power monitor	DMI_RX_Ch	-2	2	dB	
Channel Bias current monitor	DMI_Ibias_Ch	-10%	10%	mA	
Channel TX power monitor	DMI_TX_Ch	-2	2	dB	

Mechanical Specifications

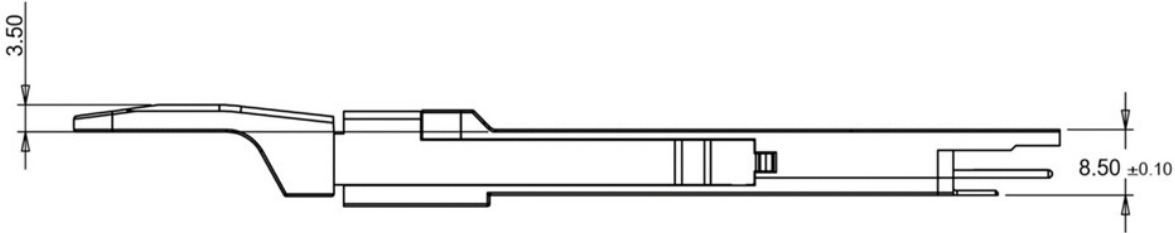
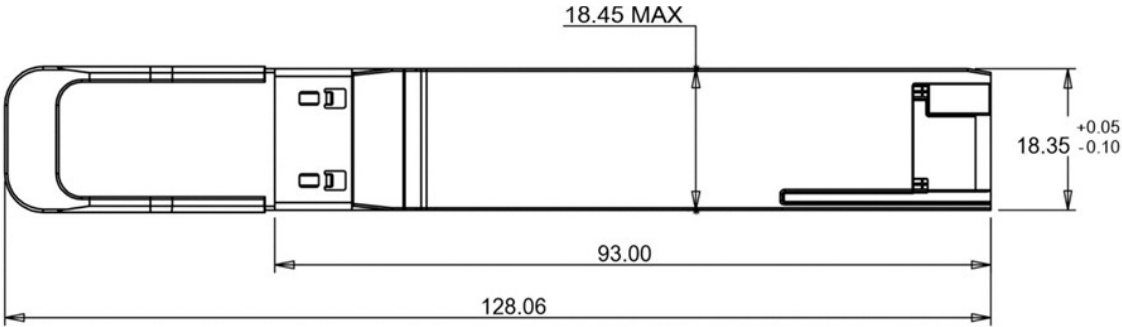

About Us:

Proline Options is one of North America's leading providers of transceivers and high speed cabling. With a reputation for quality, tested products that cover the connectivity spectrum, Proline Options has a solution for you regardless of the specification.

At Proline Options, every product is tested in its intended application - never batch or spec tested only. We run bandwidth, distance and IOS network tests. We have documented an impressive 0.03% failure rate over the last 10 years. To continue this rate of success we invest millions annually in our own on-site testing lab.



Tel: 855.933.3223

Email: sales@prolineoptions.com

Email: techsupport@prolineoptions.com

Web: <https://www.prolineoptions.com>