

Q56-2Q56-200GB-PDAC1-5MIBLZ-PRO

MSA and TAA 200GBase-CU QSFP56 to 2xQSFP56 Direct Attach Cable (Passive Twinax, 1.5m, Infiniband HDR)

Features

- PAM4 modulation
- Meet IEEE802.3bj & IEEE802.3cd
- Meet SFF-8636
- Low crosstalk
- Low power
- Support I2C two - line string interface, easy to control
- Hot pluggable
- Operating case temperature: -20 to 75 Celsius
- RoHS Compliant and Lead-Free



Applications:

- 10G/40G/100G/200GBase Ethernet
- Infiniband SDR, DDR, QDR, FDR, EDR, HDR SWITCH
- Data center, cloud server

Product Description

This is a MSA Compliant 200GBase-CU QSFP56 to 2xQSFP56 Infiniband HDR direct attach cable that operates over passive copper with a maximum reach of 1.5m. It has been programmed, uniquely serialized, and data-traffic and application tested to ensure it is 100% compliant and functional. We stand behind the quality of our products and proudly offer a limited lifetime warranty. This cable is TAA (Trade Agreements Act) compliant and is built to comply with MSA (Multi-Source Agreement) standards.

Proline’s transceivers are RoHS compliant and lead-free.

TAA refers to the Trade Agreements Act (19 U.S.C. & 2501-2581), which is intended to foster fair and open international trade. TAA requires that the U.S. Government may acquire only “U.S. – made or designated country end products.



Environment Performance

Parameter	Requirement	Test Condition
Operating Temperature Range	-20°C to +75°C	Cable operating temperature range
Storage Temperature Range (In Packed Condition)	-40°C to +80°C	Cable storage temperature range in packed condition
Thermal Cycling Non-Powered	No evidence of physical damage	EIA-364-32D, method A, -25 to 90C, 100 cycles, 15 min. dwells
Salt Spraying	48 hours salt spraying after shell corrosive area less than 5%	EIA-364-26
Mixed Flowing Gas	Pass electrical tests per 3.1 after stressing (for connector only)	EIA-364-35 Class II, 14 days
Temperature Life	No evidence of physical damage	EIA-364-17C w/RH, damp heat 90°C at 85% RH for 500 hours then return to ambient
Cable Cold Bend	4H, no evidence of physical damage	Condition: -20°C±2°C, mandrel diameter is 6 times the cable diameter
Low-Level Contact Resistance	70milliΩ maximum from initial	EIA-364-23: apply a maximum voltage of 20mV and a current of 100mA
Insulation Resistance	10MΩ (minimum)	EIA364-21: AC 300V 1 minute
Dielectric Withstanding Voltage	No disruptive discharge	EIA-364-20: apply a voltage of 300 VDC for 1 minute between adjacent terminals and between adjacent terminals and ground

Electrical Performance

Parameter		Requirement	Test Condition																																			
Differential Impedance	Cable Impedance	105+5/-10Ω	Rise time of 25ps (20-80%)																																			
	Paddle Card Impedance	100±10Ω	Rise time of 25ps (20-80%)																																			
	Cable Termination Impedance	100±15Ω	Rise time of 25ps (20-80%)																																			
Differential (Input/Output) Return Loss SDD11/SDD22		$\text{Return_loss}(f) \geq \begin{cases} 16.5-2\sqrt{f} & 0.05 \leq f < 4.1 \\ 10.66-14\log_{10}(f/5.5) & 4.1 \leq f \leq 19 \end{cases}$ <p>Where f is the frequency in GHz Return_loss(f) is the return loss at frequency f</p>	10MHz≤f ≤19GHz																																			
Differential to Common-Mode (Input/Output) Return Loss SCD11/SCD22		$\text{Return_loss}(f) \geq \begin{cases} 22-(20/25.78)f & 0.01 \leq f < 12.89 \\ 15-(6/25.78)f & 12.89 \leq f \leq 19 \end{cases}$ <p>Where f is the frequency in GHz Return_loss(f) is the Differential to common-mode return loss at frequency f</p>	10MHz≤f ≤19GHz																																			
Common-Mode to Common-Mode (Input/Output) Return Loss SCC11/SCC22		$\text{Return_loss}(f) \geq 2\text{dB} \quad 0.2 \leq f \leq 19$ <p>Where f is the frequency in GHz Return_loss(f) is the common-mode to common-mode return loss at frequency f</p>	10MHz≤f ≤19GHz																																			
Differential Insertion Loss (SDD21 Maximum)		(Differential Insertion Loss Maximum for TPa to TPb Excluding Test Fixture) <table border="1" style="margin-left: 20px;"> <thead> <tr> <th>F AWG</th> <th>1.25GHz</th> <th>2.5GHz</th> <th>5.0GHz</th> <th>7.0GHz</th> <th>10GHz</th> <th>12.89GHz</th> </tr> </thead> <tbody> <tr> <td>30 (1m) Max.</td> <td>4.5dB</td> <td>5.4dB</td> <td>6.3dB</td> <td>7.5dB</td> <td>8.5dB</td> <td>10.5dB</td> </tr> <tr> <td>30/28 (3m) Max.</td> <td>7.5dB</td> <td>9.5dB</td> <td>12.2dB</td> <td>14.8dB</td> <td>18.0dB</td> <td>21.5dB</td> </tr> <tr> <td>26 (3m) Max.</td> <td>5.7dB</td> <td>7.2dB</td> <td>9.9 dB</td> <td>11.9dB</td> <td>14.1dB</td> <td>16.5dB</td> </tr> <tr> <td>26/25 (5m) Max.</td> <td>7.8dB</td> <td>10.0dB</td> <td>13.5dB</td> <td>16.0dB</td> <td>19.0dB</td> <td>22.0dB</td> </tr> </tbody> </table>	F AWG	1.25GHz	2.5GHz	5.0GHz	7.0GHz	10GHz	12.89GHz	30 (1m) Max.	4.5dB	5.4dB	6.3dB	7.5dB	8.5dB	10.5dB	30/28 (3m) Max.	7.5dB	9.5dB	12.2dB	14.8dB	18.0dB	21.5dB	26 (3m) Max.	5.7dB	7.2dB	9.9 dB	11.9dB	14.1dB	16.5dB	26/25 (5m) Max.	7.8dB	10.0dB	13.5dB	16.0dB	19.0dB	22.0dB	10MHz≤f ≤19GHz
F AWG	1.25GHz	2.5GHz	5.0GHz	7.0GHz	10GHz	12.89GHz																																
30 (1m) Max.	4.5dB	5.4dB	6.3dB	7.5dB	8.5dB	10.5dB																																
30/28 (3m) Max.	7.5dB	9.5dB	12.2dB	14.8dB	18.0dB	21.5dB																																
26 (3m) Max.	5.7dB	7.2dB	9.9 dB	11.9dB	14.1dB	16.5dB																																
26/25 (5m) Max.	7.8dB	10.0dB	13.5dB	16.0dB	19.0dB	22.0dB																																
Insertion Loss Deviation		$-0.176*f - 0.7 \leq \text{ILD} \leq 0.176*f + 0.7$	50MHz≤f ≤19GHz																																			
Differential to Common-Mode Conversion Loss-Differential Insertion Loss (SCD21-SDD21)		$\text{Conversion_loss}(f) - \text{IL}(f) \geq \begin{cases} 10 & 0.01 \leq f < 12.89 \\ \{ 27-(29/22)f & 12.89 \leq f < 15.7 \} \\ 6.3 & 15.7 \leq f \leq 19 \end{cases}$ <p>Where f is the frequency in GHz Conversion_loss(f) is the cable assembly differential to common-mode conversion loss IL(f) is the cable assembly insertion loss</p>	10MHz≤f ≤19GHz																																			
MDNEXT (Multiple Disturber Near-End Crosstalk)		≥26dB @12.89GHz	10MHz≤f ≤19GHz																																			
Intra Skew		15ps/m	10MHz≤f ≤19GHz																																			

Mechanical and Physical Characteristics

Parameter	Requirement	Test Condition
Vibration	Pass electrical tests per 3.1 after stressing	Clamp & vibrate per EIA-364-28E, TC-VII, test condition letter – D, 15 minutes in X, Y & Z axis.
Cable Flex	No evidence of physical damage	Flex cable 180° for 20 cycles ($\pm 90^\circ$ from nominal position) at 12 cycles per minute with a 1.0kg load applied to the cable jacket. Flex in the boot area 90° in each direction from vertical. Per EIA-364-41C.
Cable Plug Retention in Cage	90N Minimum No evidence of physical damage	Force to be applied axially with no damage to cage. Per SFF-8661 Rev. 2.1. Pull on cable jacket approximately 1 ft behind cable plug. No functional damage to cable plug below 90N. Per SFF-8432 Rev. 5.0.
Cable Retention in Plug	90N Minimum No evidence of physical damage	Cable plug is fixtured with the bulk cable hanging vertically. A 90N axial load is applied (gradually) to the cable jacket and held for 1 minute. Per EIA-364-38B.
Mechanical Shock	Pass electrical tests per 3.1 after stressing	Clamp and shock per EIA-364-27B, TC-G, 3 times in 6 directions, 100g, 6ms.
Cable Plug Insertion	40N Maximum (QSFP56)	Per SFF-8661 Rev. 2.1.
Cable plug Extraction	30N Maximum (QSFP56)	Place axial load on de-latch to de-latch plug. Per SFF8661 Rev. 2.1.
Durability	50 cycles, no evidence of physical damage	EIA-364-09, perform plug & un-plug cycles: plug and receptacle mate rate: 250 times/hour. 50 times for QSFP28/SFP28 module (connector to PCB).

Electrical Pin-Out Details

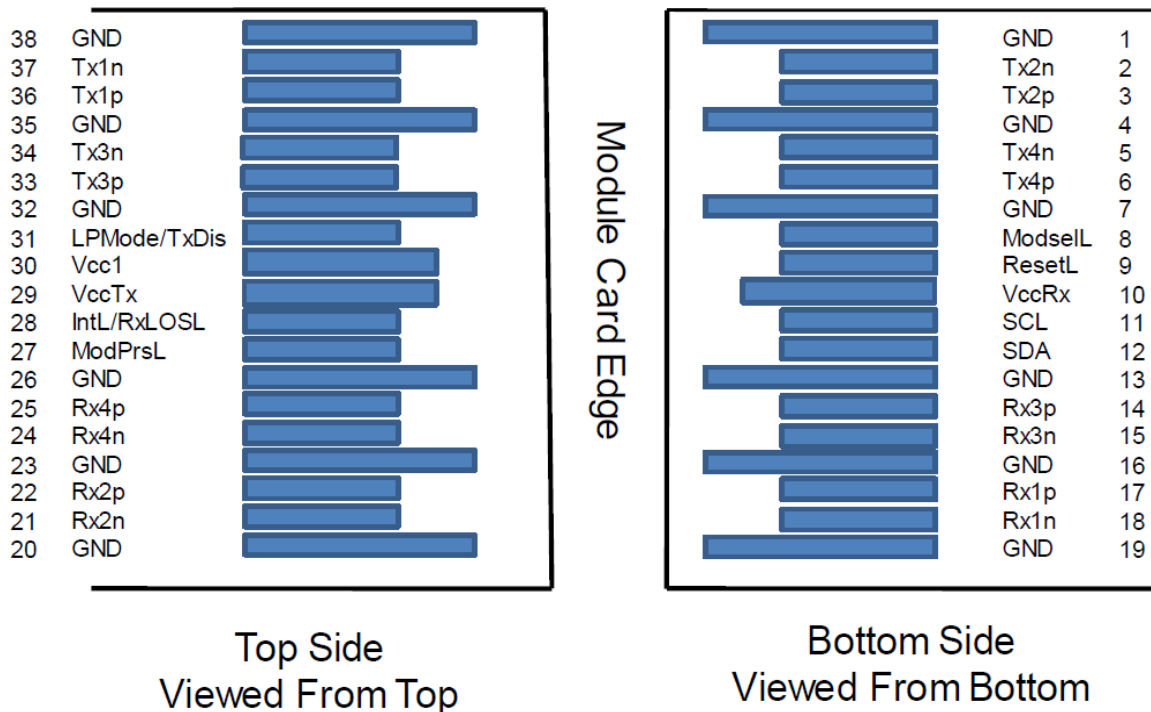

Pin Descriptions

Pin	Logic	Symbol	Name/Description	Notes
1		GND	Module Ground.	1
2	CML-I	Tx2-	Transmitter Inverted Data Input.	
3	CML-I	Tx2+	Transmitter Non-Inverted Data Input.	
4		GND	Module Ground.	1
5	CML-I	Tx4-	Transmitter Inverted Data Input.	
6	CML-I	Tx4+	Transmitter Non-Inverted Data Input.	
7		GND	Module Ground.	1
8	LVTTTL-I	ModSelL	Module Select.	
9	LVTTTL-I	ResetL	Module Reset.	
10		VccRx	+3.3V Receiver Power Supply.	2
11	LVC MOS-I/O	SCL	2-Wire Serial Interface Clock.	
12	LVC MOS-I/O	SDA	2-Wire Serial Interface Data.	
13		GND	Module Ground.	1
14	CML-O	Rx3+	Receiver Non-Inverted Data Output.	
15	CML-O	Rx3-	Receiver Inverted Data Output.	
16		GND	Module Ground.	1
17	CML-O	Rx1+	Receiver Non-Inverted Data Output.	
18	CML-O	Rx1-	Receiver Inverted Data Output.	
19		GND	Module Ground.	1
20		GND	Module Ground.	1
21	CML-O	Rx2-	Receiver Inverted Data Output.	
22	CML-O	Rx2+	Receiver Non-Inverted Data Output.	
23		GND	Module Ground.	1
24	CML-O	Rx4-	Receiver Inverted Data Output.	
25	CML-O	Rx4+	Receiver Non-Inverted Data Output.	
26		GND	Module Ground.	1
27	LVTTTL-O	ModPrsL	Module Present.	
28	LVTTTL-O	IntL	Interrupt.	
29		VccTx	+3.3V Transmitter Power Supply.	2
30		Vcc1	+3.3V Power Supply.	2
31	LVTTTL-I	LPMode	Low-Power Mode.	
32		GND	Module Ground.	1
33	CML-I	Tx3+	Transmitter Non-Inverted Data Input.	
34	CML-I	Tx3-	Transmitter Inverted Data Input.	

35		GND	Module Ground.	1
36	CML-I	Tx1+	Transmitter Non-Inverted Data Input.	
37	CML-I	Tx1-	Transmitter Inverted Data Input.	
38		GND	Module Ground.	1

Note:

- GND is the symbol for signal and supply (power) common for the QSFP module. All are common within the QSFP module, and all module voltages are referenced to this potential unless otherwise noted. Connect these directly to the host board signal-common ground plane.
- VccRx, Vcc1, and VccTx are the receiver and transmitter power supplies and shall be applied concurrently. VccRx, Vcc1, and VccTx may be internally connected within the QSFP transceiver module in any combination. The connector pins are each rated for a maximum current of 500mA.

Wiring Diagram

wire	Starting signal	Starting	End	End signal
W1	RX1+	X1.17	X2.36	TX1+
	RX1-	X1.18	X2.37	TX1-
	GND	X1.19	X2.38	GND
	TX1+	X1.36	X2.17	RX1+
	TX1-	X1.37	X2.18	RX1-
	GND	X1.38	X2.19	GND
W2	GND	X1.20	X2.1	GND
	RX2-	X1.21	X2.2	TX2-
	RX2+	X1.22	X2.3	TX2+
	GND	X1.1	X2.20	GND
	TX2-	X1.2	X2.21	RX2-
	TX2+	X1.3	X2.22	RX2+
W3	RX3+	X1.14	X3.36	TX1+
	RX3-	X1.15	X3.37	TX1-
	GND	X1.16	X3.38	GND
	TX3+	X1.33	X3.17	RX1+
	TX3-	X1.34	X3.18	RX1-
	GND	X1.35	X3.19	GND
W4	GND	X1.23	X3.1	GND
	RX4-	X1.24	X3.2	TX2-
	RX4+	X1.25	X3.3	TX2+
	GND	X1.4	X3.20	GND
	TX4-	X1.5	X3.21	RX2-
	TX4+	X1.6	X3.22	RX2+

Mechanical Specifications

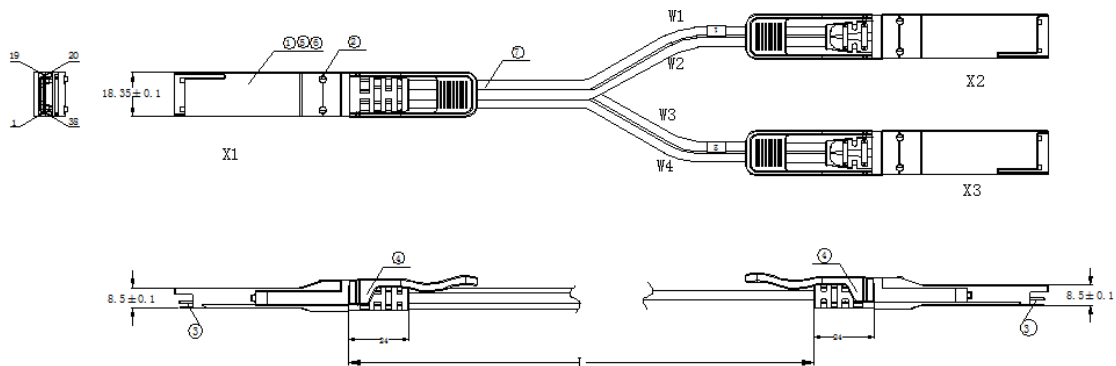

About Us:

Proline Options is one of North America's leading providers of transceivers and high speed cabling. With a reputation for quality, tested products that cover the connectivity spectrum, Proline Options has a solution for you regardless of the specification.

At Proline Options, every product is tested in its intended application - never batch or spec tested only. We run bandwidth, distance and IOS network tests. We have documented an impressive 0.03% failure rate over the last 10 years. To continue this rate of success we invest millions annually in our own on-site testing lab.



Tel: 855.933.3223

Email: sales@prolineoptions.com

Email: techsupport@prolineoptions.com

Web: <https://www.prolineoptions.com>