

MMS4X00-NS400-PRO

Mellanox® MMS4X00-NS400 Compatible TAA 400GBase-DR4 PAM4 OSFP112 RHS Transceiver (SMF, 1310nm, 500m, MPO, DOM, CMIS 5.0)

Features

- 4x100G PAM4 Data Rates
- Hot Pluggable OSFP Form Factor
- Single 3.3V Power Supply
- I2C Management Interface Compliant to CMIS Rev5.0
- Compliant with IEEE 802.3 bs 400GBASE-DR4
- Electrical Interface Compliant with 100Gbps Per Lane Defined by IEEE 802.3ck
- Internal CDR on Both Transmitter and Receiver Channels
- PIN Receiver
- Operating Temperature: 0 to 70 Celsius
- Cooled 1310nm EML Laser
- RoHS Compliant and Lead-Free



Applications:

- 400GBase Ethernet

Product Description

This Mellanox® MMS4X00-NS400 compatible OSFP112 RHS transceiver provides 400GBase-DR4 throughput up to 500m over single-mode fiber (SMF) using a wavelength of 1310nm via an MPO connector. It is guaranteed to be 100% compatible with the equivalent Mellanox® transceiver. This easy to install, hot swappable transceiver has been programmed, uniquely serialized and data-traffic and application tested to ensure that it will initialize and perform identically. Digital optical monitoring (DOM) support is also present to allow access to real-time operating parameters. This transceiver is Trade Agreements Act (TAA) compliant. We stand behind the quality of our products and proudly offer a limited lifetime warranty.

Proline's transceivers are RoHS compliant and lead-free.

TAA refers to the Trade Agreements Act (19 U.S.C. & 2501-2581), which is intended to foster fair and open international trade. TAA requires that the U.S. Government may acquire only "U.S. – made or designated country end products.



Absolute Maximum Ratings

Parameter	Symbol	Min.	Typ.	Max.	Unit
Maximum Supply Voltage	Vcc	-0.5		3.6	V
Supply Voltage	Vcc	3.13	3.3	3.47	V
Storage Temperature	Tstg	-40		85	°C
Operating Temperature	Tc	0	40	70	°C
Relative Humidity	RH	15		85	%
Data Rate			106.25±100ppm		Gbps

Notes:

1. Stressed in excess of the Absolute Maximum Ratings can cause permanent damage to the device. These are absolute stress ratings only. Functional operation of the device is not implied at these or any other conditions in excess of those given in the operational sections of the datasheet. Exposure to Absolute Maximum Ratings for extended periods can adversely affect device reliability.

Electrical Characteristics

Parameter	Symbol	Min.	Typ.	Max.	Unit	Notes
Module Supply Current	Icc			2.87	A	
Power Dissipation	P _{DISS}			9	W	
Transmitter						
Input Differential Impedance	ZIN	90	100	110	Ω	
Differential Data Input Swing	VIN,pp			900	mVp-p	
DC Common-Mode Input Voltage		-350		2850	mV	
Receiver						
Output Differential Impedance	ZOUT	90	100	110	Ω	
Differential Data Output Swing	VOUT,pp			900	mVp-p	1
Dual Function Signals						
INT/RSTn	V_INT/RSTn_1	0.000	0.000	1.000	V	2
	V_INT/RSTn_2	0.000	0.000	1.000	V	3
	V_INT/RSTn_3	1.500	1.900	2.250	V	4
	V_INT/RSTn_4	2.750	3.000	3.465	V	5
LPWn/PRSn	V_LPWn/PRSn_1	0.000	0.950	1.100	V	6
	V_LPWn/PRSn_2	1.400	1.700	2.250	V	7
	V_LPWn/PRSn_3	2.750	3.300	3.465	V	8

Notes:

1. Internally AC coupled but requires an external 100Ω differential load termination.
2. INT/RSTn voltage for no Module.

3. INT/RSTn voltage for Module installed, H_RSTn=Low.
4. INT/RSTn voltage for Module installed, H_RSTn=High, M_INT=Low.
5. INT/RSTn voltage for Module installed, H_RSTn=High, M_INT= High.
6. LPWn/PRSn voltage for Module installed, H_LPWn=Low.
7. LPWn/PRSn voltage for Module installed, H_LPWn =High.
8. LPWn/PRSn voltage for no Module.

Optical Characteristics

Parameter	Symbol	Min.	Typ.	Max.	Unit	Notes
Transmitter						
Average Launch Power Per Lane	Pavg	-2.9		4	dBm	1
Outer Optical Modulation Amplitude Per Lane	POMA	-0.8		4.2	dBm	1
Extinction Ratio	ER	3.5			dB	
Lane Wavelengths	λ	1304.5		1317.5	nm	
Side-Mode Suppression Ratio	SMSR	30			dB	
Transmitter and Dispersion Penalty Eye Closure Per Lane	TDECQ			3.4	dB	
Launch Power in OMAouter Minus TDECQ Per Lane	OMA-TDECQ	-2.2			dBm	
Average Launch Power of Off Transmitter	Poff			-15	dBm	
Optical Return Loss Tolerance	ORLT			21.4	dB	
Transmitter Reflectance				-26	dB	
Receiver						
Lane Wavelengths	λ	1304.5		1317.5	nm	
Receiver Sensitivity (OMA)	RxSENS			-3.9	dBm	2
Receiver Overload Per Lane (Pavg)	POL	4			dBm	
Damage Threshold Per Lane		5			dBm	
Receiver Power Per Lane (OMAouter)	OMA			4.2	dBm	
Receiver Reflectance				-26	dB	
LOS De-Assert	LOSD			-10	dBm	
LOS Assert	LOSA	-16			dBm	
LOS Hysteresis		0.5			dB	

Notes:

1. Class 1 Laser Safety per FDA/CDRH and EN (IEC) 60825 regulations.
2. Measured with PRBS31Q test pattern, 53.125GBd, PAM4, and BER<2.4E⁻⁴.

Pin Descriptions

Pin	Logic	Symbol	Name/Description	Direction	Plug Sequence	Notes
1		GND	Module Ground.		1	
2	CML-I	Tx2+	Transmitter Non-Inverted Data.	Input from Host	3	
3	CML-I	Tx2-	Transmitter Inverted Data.	Input from Host	3	
4		GND	Module Ground.		1	
5	CML-I	Tx4+	Transmitter Non-Inverted Data.	Input from Host	3	
6	CML-I	Tx4-	Transmitter Inverted Data.	Input from Host	3	
7		GND	Module Ground.		1	
8	CML-I	Tx6+	Transmitter Non-Inverted Data.	Input from Host	3	
9	CML-I	Tx6-	Transmitter Inverted Data.	Input from Host	3	
10		GND	Module Ground.		1	
11	CML-I	Tx8+	Transmitter Non-Inverted Data.	Input from Host	3	
12	CML-I	Tx8-	Transmitter Inverted Data.	Input from Host	3	
13		GND	Module Ground.		1	
14	LVC MOS-I/O	SCL	2-Wire Serial Interface Clock.	Bi-Directional	3	1
15		Vcc	+3.3V Power Supply.	Power from Host	2	
16		Vcc	+3.3V Power Supply.	Power from Host	2	
17	Multi-Level	LPWn/PRSn	Low-Power Mode/Module Present.	Bi-Directional	3	2
18		GND	Module Ground.		1	
19	CML-O	Rx7-	Receiver Inverted Data.	Output to Host	3	
20	CML-O	Rx7+	Receiver Non-Inverted Data.	Output to Host	3	
21		GND	Module Ground.		1	
22	CML-O	Rx5-	Receiver Inverted Data.	Output to Host	3	
23	CML-O	Rx5+	Receiver Non-Inverted Data.	Output to Host	3	
24		GND	Module Ground.		1	
25	CML-O	Rx3-	Receiver Inverted Data.	Output to Host	3	
26	CML-O	Rx3+	Receiver Non-Inverted Data.	Output to Host	3	
27		GND	Module Ground.		1	
28	CML-O	Rx1-	Receiver Inverted Data.	Output to Host	3	
29	CML-O	Rx1+	Receiver Non-Inverted Data.	Output to Host	3	
30		GND	Module Ground.		1	
31		GND	Module Ground.		1	
32	CML-O	Rx2+	Receiver Non-Inverted Data.	Output to Host	3	
33	CML-O	Rx2-	Receiver Inverted Data.	Output to Host	3	
34		GND	Module Ground.		1	
35	CML-O	Rx4+	Receiver Non-Inverted Data.	Output to Host	3	

36	CML-O	Rx4-	Receiver Inverted Data.	Output to Host	3	
37		GND	Module Ground.		1	
38	CML-O	Rx6+	Receiver Non-Inverted Data.	Output to Host	3	
39	CML-O	Rx6-	Receiver Inverted Data.	Output to Host	3	
40		GND	Module Ground.		1	
41	CML-O	Rx8+	Receiver Non-Inverted Data.	Output to Host	3	
42	CML-O	Rx8-	Receiver Inverted Data.	Output to Host	3	
43		GND	Module Ground.		1	
44	Multi-Level	INT/RSTn	Module Interrupt/Module Reset.	Bi-Directional	3	2
45		Vcc	+3.3V Power Supply.	Power from Host	2	
46		Vcc	+3.3V Power Supply.	Power from Host	2	
47	LVC MOS-I/O	SDA	2-Wire Serial Interface Data.	Bi-Directional	3	1
48		GND	Module Ground.		1	
49	CML-I	Tx7-	Transmitter Inverted Data.	Input from Host	3	
50	CML-I	Tx7+	Transmitter Non-Inverted Data.	Input from Host	3	
51		GND	Module Ground.		1	
52	CML-I	Tx5-	Transmitter Inverted Data.	Input from Host	3	
53	CML-I	Tx5+	Transmitter Non-Inverted Data.	Input from Host	3	
54		GND	Module Ground.		1	
55	CML-I	Tx3-	Transmitter Inverted Data.	Input from Host	3	
56	CML-I	Tx3+	Transmitter Non-Inverted Data.	Input from Host	3	
57		GND	Module Ground.		1	
58	CML-I	Tx1-	Transmitter Inverted Data.	Input from Host	3	
59	CML-I	Tx1+	Transmitter Non-Inverted Data.	Input from Host	3	
60		GND	Module Ground.		1	

Notes:

1. Open-drain with pull-up resistor on the host.
2. See pin description of OSFP MSA for required circuit.

Electrical Pad Layout

Top Side (viewed from top)



Bottom Side (viewed from bottom)

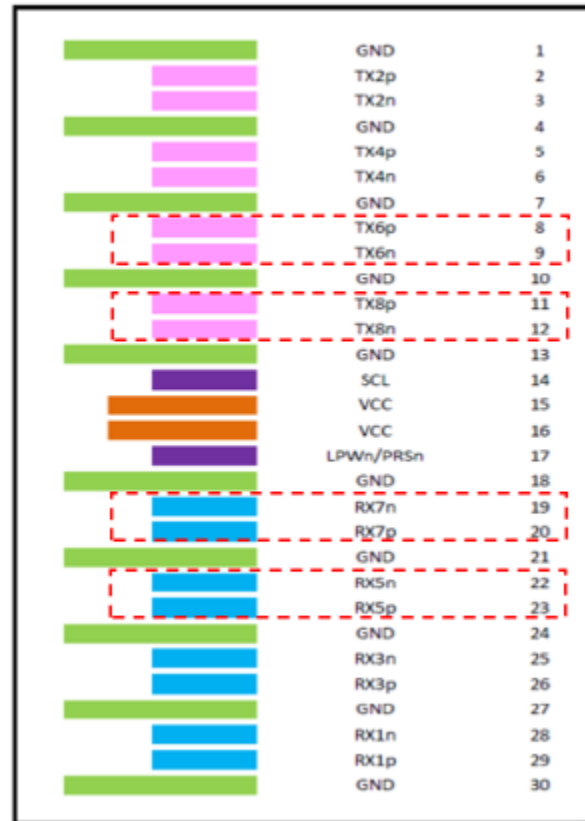

----- Module Card Edge -----

Block Diagram

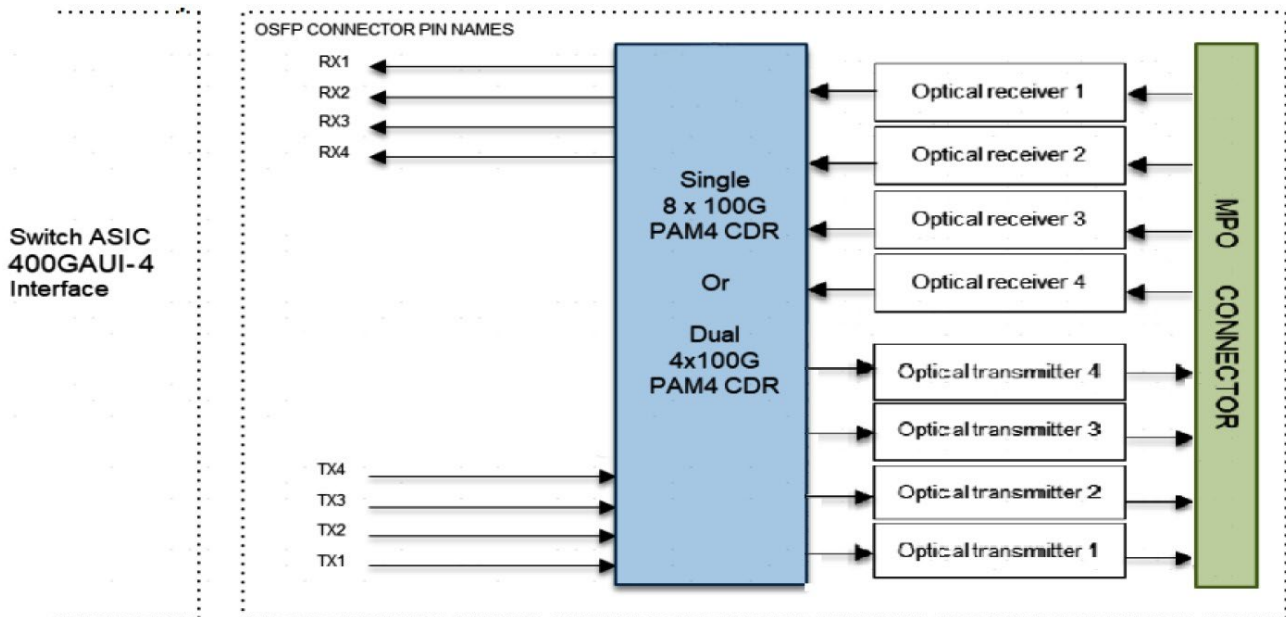

Recommended Application Interface Block Diagram

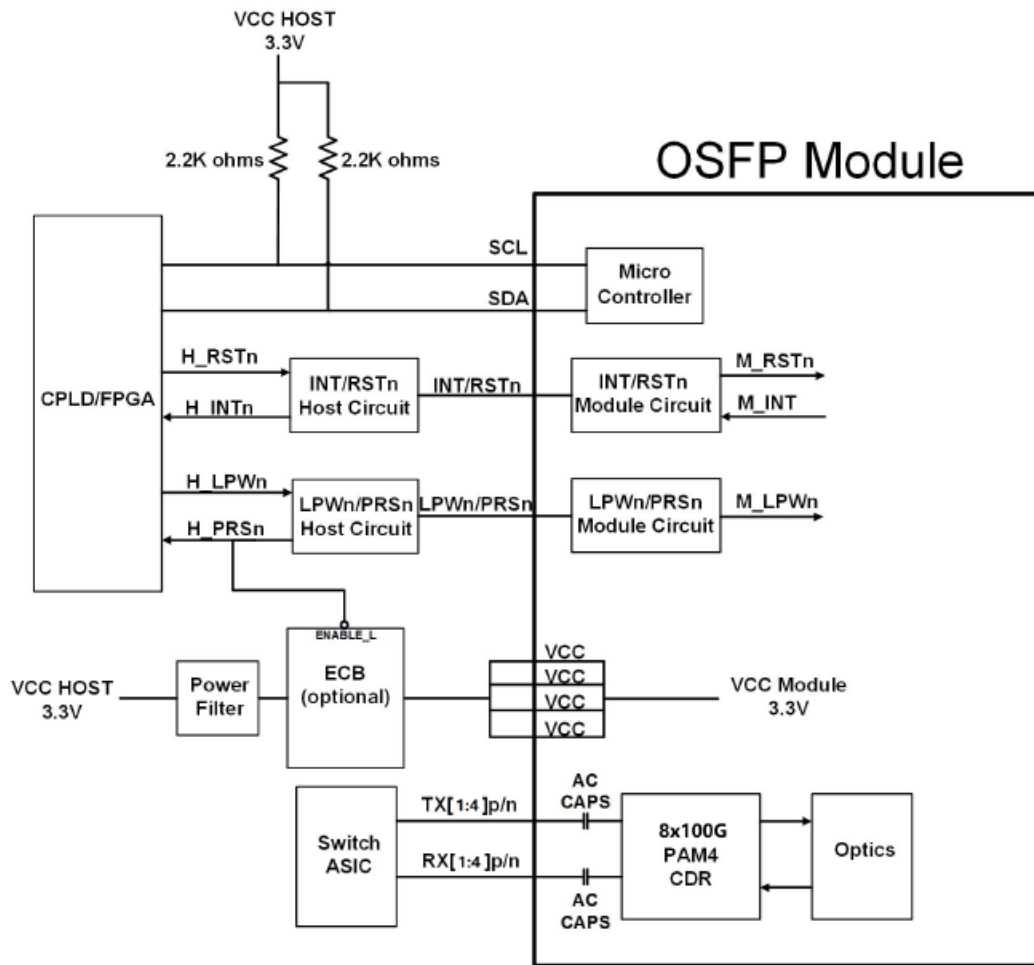

Recommended Host Board Power Supply Filter Network

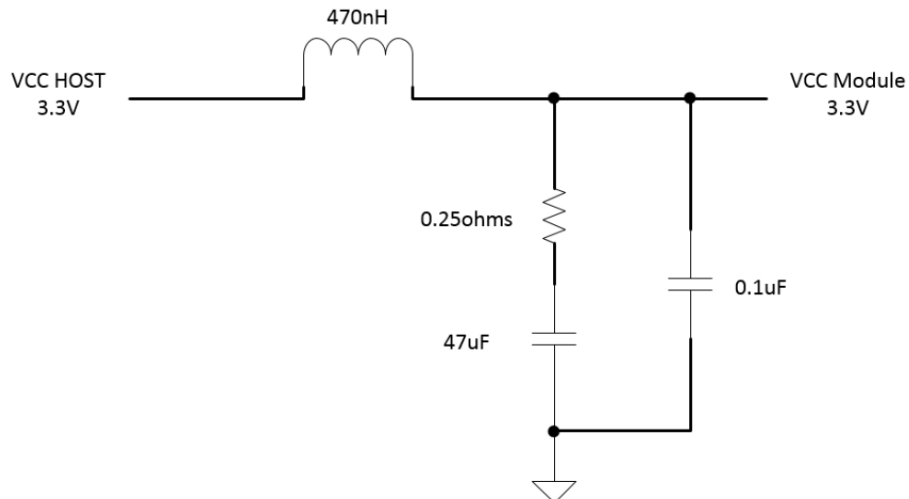

About Us:

Proline Options is one of North America's leading providers of transceivers and high speed cabling. With a reputation for quality, tested products that cover the connectivity spectrum, Proline Options has a solution for you regardless of the specification.

At Proline Options, every product is tested in its intended application - never batch or spec tested only. We run bandwidth, distance and IOS network tests. We have documented an impressive 0.03% failure rate over the last 10 years. To continue this rate of success we invest millions annually in our own on-site testing lab.



Tel: 855.933.3223

Email: sales@prolineoptions.com

Email: techsupport@prolineoptions.com

Web: <https://www.prolineoptions.com>