

MMA4Z00-NS400-PRO

Mellanox® MMA4Z00-NS400 Compatible TAA Compliant 400GBase-SR4 PAM4 OSFP112 RHS Transceiver (MMF, 850nm, 50m, DOM, CMIS 5.0, 0 to 70C, MPO)

Features

- OSFP MSA Compliant
- Bi-directional operation: 4x Tx, and 4x Rx at 106.25Gbps with 53.125GBd PAM4 modulation scheme
- Compliant with IEEE 802.3db 400GBASE-SR4
- Commercial Temperature: 0 to 70 Celsius
- VCSEL Transmitter
- Single MPO-12 Connector
- Hot Pluggable
- Built in DSP
- RoHS Compliant and Lead-Free



Applications:

- 400GBase Ethernet
- 1x Fibre Channel
- Access and Enterprise

Product Description

This Mellanox® MMA4Z00-NS400 compatible OSFP112 RHS transceiver provides 400GBase-SR4 throughput up to 50m over multi-mode fiber (MMF) using a wavelength of 850nm via an MPO connector. It is guaranteed to be 100% compatible with the equivalent Mellanox® transceiver. This easy to install, hot swappable transceiver has been programmed, uniquely serialized and data-traffic and application tested to ensure that it will initialize and perform identically. Digital optical monitoring (DOM) support is also present to allow access to real-time operating parameters. This transceiver is Trade Agreements Act (TAA) compliant. We stand behind the quality of our products and proudly offer a limited lifetime warranty.

Proline's transceivers are RoHS compliant and lead-free.

TAA refers to the Trade Agreements Act (19 U.S.C. & 2501-2581), which is intended to foster fair and open international trade. TAA requires that the U.S. Government may acquire only "U.S. – made or designated country end products.



Absolute Maximum Ratings

Parameter	Symbol	Min.	Typ.	Max.	Unit	Notes
Power Supply Voltage	Vcc	-0.3		3.6	V	
Storage Temperature	Tstg	-40		+85	°C	
Operating Case Temperature	Tc	0		70	°C	1
Relative Humidity (non-condensing)	RH	5		85	%	
Data rate	DR		106.25		Gbps	
ESD		-1000		+1000	V	High speed
		-2000		+2000	V	Others

Notes:

1. Exceeding the Absolute Maximum Ratings table may cause permanent damage to the device. This is just an emphasized rating and does not involve the functional operation of the device that exceeds the specifications of this technical specification under these or other conditions. Long-term operation under Absolute Maximum Ratings will affect the reliability of the device.

Electrical Characteristics

Parameter	Symbol / Test Point	Min.	Typ.	Max.	Unit	Notes
Power Supply Voltage	Vcc	3.135	3.3	3.465	V	
Transceiver Power Consumption	TD			8.5	W	
Transmitter Input Specifications						
RX Signaling Rate	TP1a				GBd	
Single-Ended Voltage Tolerance Range	TP1a	-0.4		3.3	V	
DC Common-Mode Voltage	TP1a	-0.3		2.8	V	
AC Common Mode Output Voltage (rms)	TP1a			32 (LF) 80 (Full Band)	mV	
Eye Height	TP1a	10			mV	
Vertical Eye Closure (VEC)				12	dB	
Effective Return Loss		7.3			dB	
Differential Pk-Pk Input Voltage		35		750	mV	
Rx Differential Termination Mismatch	TP1			10	%	
Receiver Output Specifications						
AC Common Mode Output Voltage (rms)	TP4			32 (LF) 80 (Full Band)	mV	
Differential Pk-Pk Output Voltage	TP4			600 (short mode) 845 (long mode)	mV	
Eye Height, Differential	TP4	15			mV	
Effective Return Loss, ERL	TP4	8.5			dB	
Differential Termination Mismatch	TP4			10	%	

Transition Time (min, 20% to 80%)	TP4	8.5			ps	
DC Common Mode Voltage	TP4	-350		2850	mV	

Optical Characteristics

Parameter	Symbol	Min.	Typ.	Max.	Unit	Notes
Transmitter (@TP2 Test Point)						
Tx Optical Power	TxP	-4.6		4	dBm	
Extinction Ratio	ER	2.5			dB	
Outer Optical Modulation Amplitude (OMA _{outer})	POMA	-2.6dBm max (TECQ, TDECQ) <1.8dB -4.4dBm + max (TECQ, TDECQ) 1.8<max (TECQ, TDE CQ)<=4.4dB		3.5	dBm	
Average Launch Power of OFF Transmitter, each Lane	Poff			-30	dBm	
Wavelength Range	λ	840		868	nm	
Spectral Width	RMS			0.6	nm	
RIN ₁₂ OMA	RIN ₁₂ OMA			-132	dB/Hz	
Optical Return Loss Tolerance	ORL			14	dB	
Transmitter and Dispersion Eye Closure for PAM4 (TDECQ)				4.4	dB	
Receiver (@TP3 Test Point)						
Damage Threshold		5			dBm	1
Average Receiver Power		-6.4		4	dBm	
Average Receiver Power, each Lane	OMA _{outer}			3.5	dBm	
Center Wavelength	λ	840		868	nm	
Receiver Reflectance				-15	dB	
Receiver Sensitivity (OMA _{outer}) @2 ¹⁰ ⁻⁴	SEN			Max (-4.6, SECQ-6.4)	dBm	
Stressed Receiver Sensitivity (OMA _{outer})				-2	dBm	
SECQ		4.4			dB	
OMA _{outer} of each aggressor lane		3.5			dBm	

Notes:

1. The receiver shall be able to tolerate, without damage, continuous exposure to an optical input signal having this average power level on one lane. The receiver does not have to operate correctly at this input power.

Pin Descriptions

Pin	Logic	Symbol	Name/Description	Plug Sequence	Notes
1		GND	Module Ground.	1	1
2	CML-I	Tx2+	Transmitter Non-Inverted Data.	3	
3	CML-I	Tx2-	Transmitter Inverted Data.	3	
4		GND	Module Ground.	1	1
5	CML-I	Tx4+	Transmitter Non-Inverted Data.	3	
6	CML-I	Tx4-	Transmitter Inverted Data.	3	
7		GND	Module Ground.	1	1
8	CML-I	Tx6+	Transmitter Non-Inverted Data.	3	
9	CML-I	Tx6-	Transmitter Inverted Data.	3	
10		GND	Module Ground.	1	1
11	CML-I	Tx8+	Transmitter Non-Inverted Data.	3	
12	CML-I	Tx8-	Transmitter Inverted Data.	3	
13		GND	Module Ground.	1	1
14	LVC MOS-I/O	SCL	2-Wire Serial Interface Clock.	3	2
15		Vcc	+3.3V Power Supply.	2	
16		Vcc	+3.3V Power Supply.	2	
17	Multi-Level	LPWn/PRSn	Low-Power Mode/Module Present.	3	
18		GND	Module Ground.	1	1
19	CML-O	Rx7-	Receiver Inverted Data.	3	
20	CML-O	Rx7+	Receiver Non-Inverted Data.	3	
21		GND	Module Ground.	1	1
22	CML-O	Rx5-	Receiver Inverted Data.	3	
23	CML-O	Rx5+	Receiver Non-Inverted Data.	3	
24		GND	Module Ground.	1	1
25	CML-O	Rx3-	Receiver Inverted Data.	3	
26	CML-O	Rx3+	Receiver Non-Inverted Data.	3	
27		GND	Module Ground.	1	1
28	CML-O	Rx1-	Receiver Inverted Data.	3	
29	CML-O	Rx1+	Receiver Non-Inverted Data.	3	
30		GND	Module Ground.	1	1
31		GND	Module Ground.	1	1
32	CML-O	Rx2+	Receiver Non-Inverted Data.	3	
33	CML-O	Rx2-	Receiver Inverted Data.	3	
34		GND	Module Ground.	1	1
35	CML-O	Rx4+	Receiver Non-Inverted Data.	3	

36	CML-O	Rx4-	Receiver Inverted Data.	3	
37		GND	Module Ground.	1	1
38	CML-O	Rx6+	Receiver Non-Inverted Data.	3	
39	CML-O	Rx6-	Receiver Inverted Data.	3	
40		GND	Module Ground.	1	1
41	CML-O	Rx8+	Receiver Non-Inverted Data.	3	
42	CML-O	Rx8-	Receiver Inverted Data.	3	
43		GND	Module Ground.	1	1
44	Multi-Level	INT/RSTn	Module Input/Module Reset.	3	
45		Vcc	+3.3V Power Supply.	2	
46		Vcc	+3.3V Power Supply.	2	
47	LVC MOS-I/O	SDA	2-Wire Serial Interface Data.	3	2
48		GND	Module Ground.	1	1
49	CML-I	Tx7-	Transmitter Inverted Data.	3	
50	CML-I	Tx7+	Transmitter Non-Inverted Data.	3	
51		GND	Module Ground.	1	1
52	CML-I	Tx5-	Transmitter Inverted Data.	3	
53	CML-I	Tx5+	Transmitter Non-Inverted Data.	3	
54		GND	Module Ground.	1	1
55	CML-I	Tx3-	Transmitter Inverted Data.	3	
56	CML-I	Tx3+	Transmitter Non-Inverted Data.	3	
57		GND	Module Ground.	1	1
58	CML-I	Tx1-	Transmitter Inverted Data.	3	
59	CML-I	Tx1+	Transmitter Non-Inverted Data.	3	
60		GND	Module Ground.	1	1

Notes:

1. OSFP uses common ground (GND) for all signals and supply (power). All are common within the OSFP module, and all module voltages are referenced to this potential unless otherwise noted.
2. Open-Drain with pull-up resistor on the host.

Electrical Pad Layout

Top Side (viewed from top)

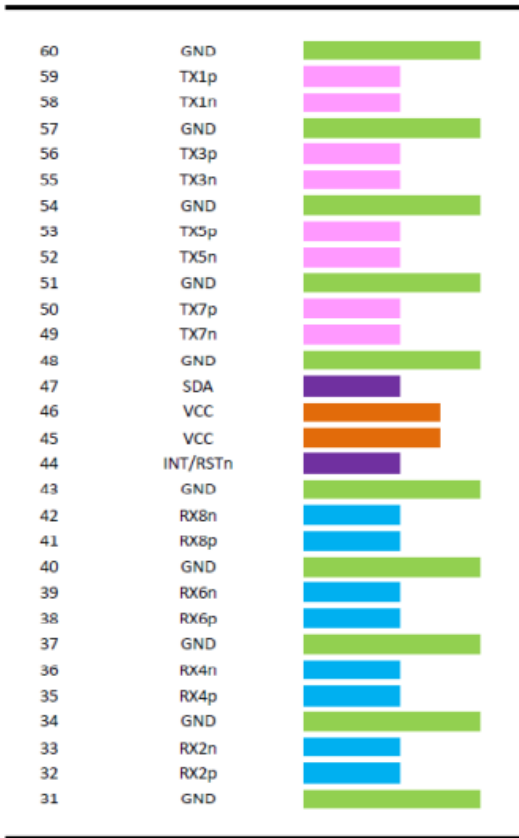

----- Module Card Edge -----

Bottom Side (viewed from bottom)

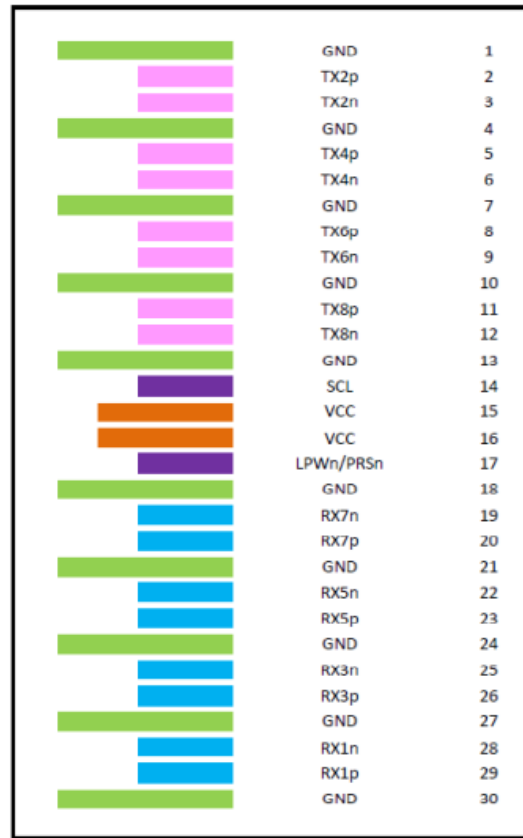

Test Compliance Points

Reference link model and test compliance points used in product specifications are illustrated as follows.

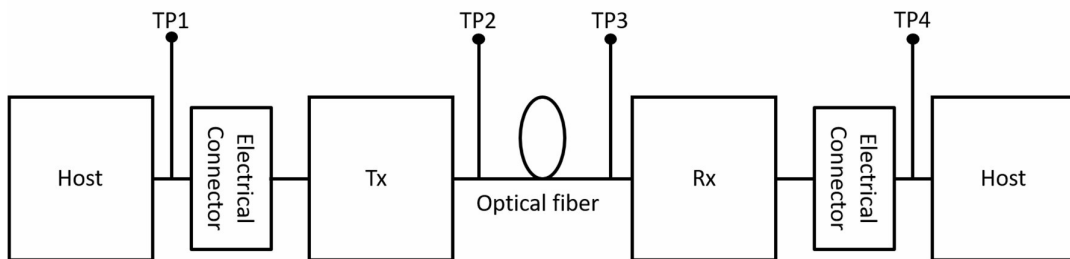

Transceiver Block Diagram

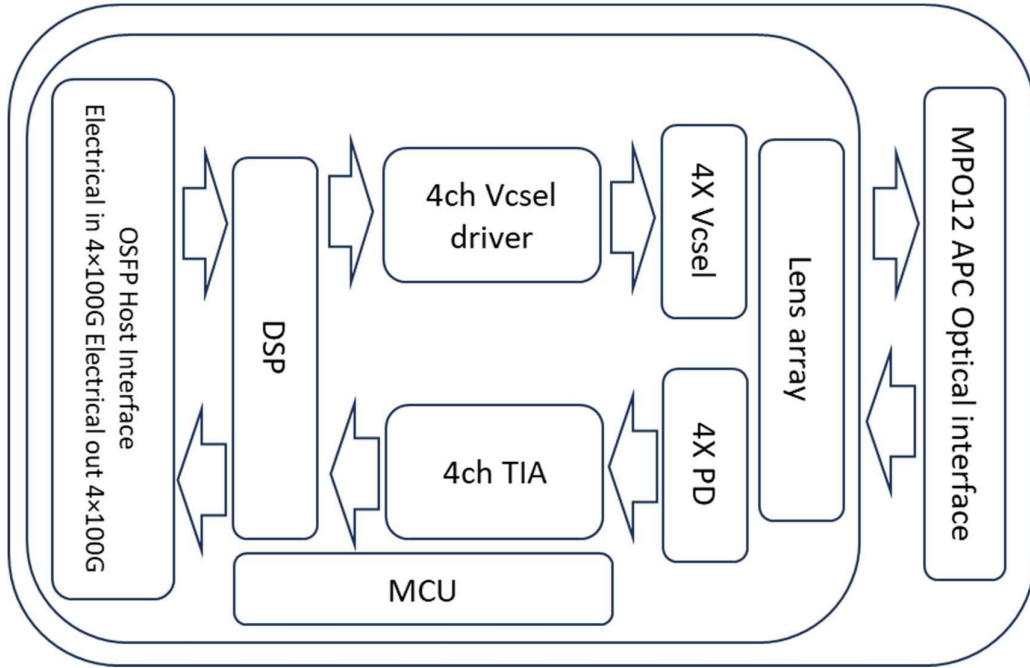

Mechanical Specifications

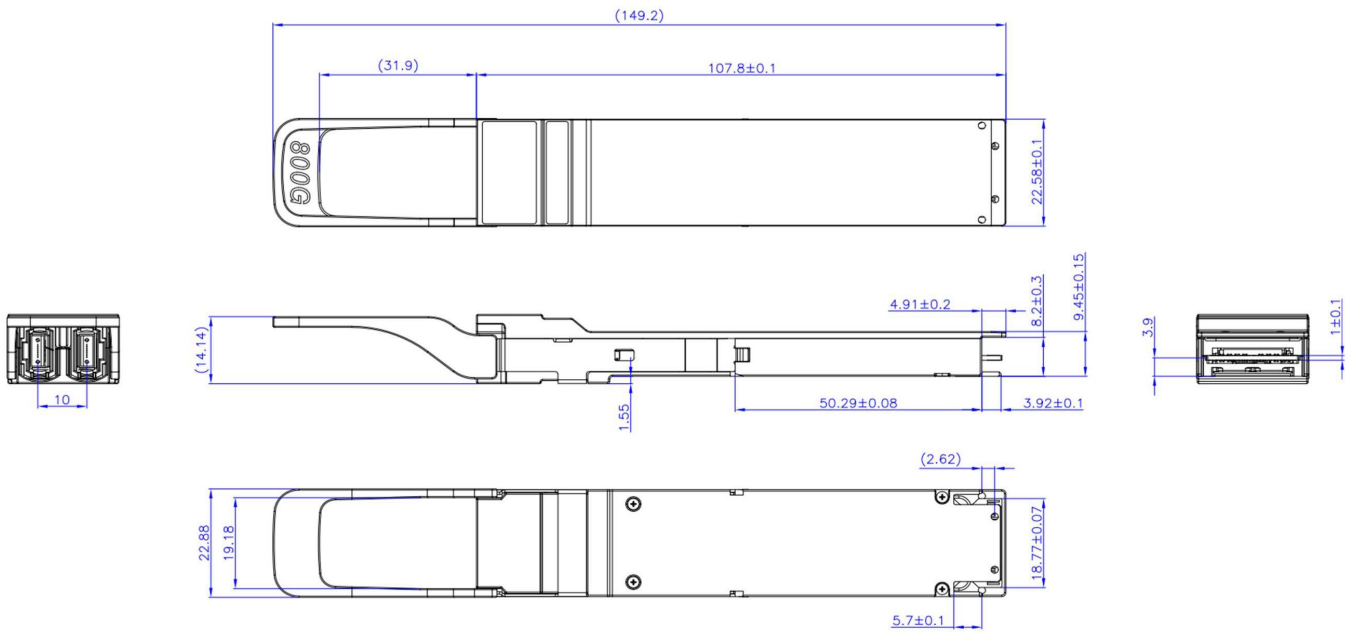

About Us:

Proline Options is one of North America's leading providers of transceivers and high speed cabling. With a reputation for quality, tested products that cover the connectivity spectrum, Proline Options has a solution for you regardless of the specification.

At Proline Options, every product is tested in its intended application - never batch or spec tested only. We run bandwidth, distance and IOS network tests. We have documented an impressive 0.03% failure rate over the last 10 years. To continue this rate of success we invest millions annually in our own on-site testing lab.



Tel: 855.933.3223

Email: sales@prolineoptions.com

Email: techsupport@prolineoptions.com

Web: <https://www.prolineoptions.com>