

## JL274A-PRO

HP® JL274A Compatible TAA Compliant 100GBase-SR4 QSFP28 Transceiver (MMF, 850nm, 100m, DOM, 0 to 70C, MPO)

### Features

- SFF-8665 Compliance
- MPO Connector
- Commercial Temperature 0 to 70 Celsius
- Multi-mode Fiber
- Hot Pluggable
- Excellent ESD Protection
- Metal with Lower EMI
- RoHS Compliant and Lead Free



### Applications:

- 100GBase Ethernet
- Access and Enterprise

### Product Description

This HP® JL274A compatible QSFP28 transceiver provides 100GBase-SR4 throughput up to 100m over OM4 multi-mode fiber (MMF) using a wavelength of 850nm via an MPO connector. It is guaranteed to be 100% compatible with the equivalent HP® transceiver. This easy to install, hot swappable transceiver has been programmed, uniquely serialized and data-traffic and application tested to ensure that it will initialize and perform identically. Digital optical monitoring (DOM) support is also present to allow access to real-time operating parameters. This transceiver is Trade Agreements Act (TAA) compliant. We stand behind the quality of our products and proudly offer a limited lifetime warranty.

Proline's transceivers are RoHS compliant and lead-free.

TAA refers to the Trade Agreements Act (19 U.S.C. & 2501-2581), which is intended to foster fair and open international trade. TAA requires that the U.S. Government may acquire only "U.S. – made or designated country end products.



## Absolute Maximum Ratings

Parameter	Symbol	Min.	Typ.	Max.	Unit	Notes
Maximum Supply Voltage	V <sub>CC</sub>	-0.5		4.0	V	
Storage Temperature	T <sub>S</sub>	-40		+85	°C	
Relative Humidity	RH	5		95	%	
Operating Case Temperature	T <sub>C</sub>	0	25	70	°C	
Data Rate PER Channel	DR		25.78125		Gb/s	

## Electrical Characteristics

Parameter	Symbol	Min.	Typ.	Max.	Unit	Notes
Supply Voltage	V <sub>CC</sub>	3.135	3.3	3.465	V	
Module Supply Current	I <sub>CC</sub>			750	mA	
Power Dissipation	P <sub>D</sub>			2.5	W	
<b>Transmitter</b>						
Input Differential Impedance	Z <sub>IN</sub>		100		Ω	
Differential Data Input Swing	V <sub>IN, P-P</sub>	180		900	mVp-p	
<b>Receiver</b>						
Output Differential Impedance	Z <sub>O</sub>		100		Ω	
Differential Data Output Swing	V <sub>OUT, P-P</sub>	300		850	mVp-p	1
Transition Time (20% to 80%)	T <sub>r, T<sub>f</sub></sub>	12			ps	

### Notes:

1. The optical power is launched into OM3 MMF.
2. Measured with a PRBS 2<sup>31</sup>-1 test pattern @25.78125Gbps.

## Optical Characteristics

Parameter	Symbol	Min.	Typ.	Max.	Unit.	Notes
<b>Transmitter</b>						
Launch Optical Power	P <sub>o</sub>	-8.4		+2.4	dBm	1
Center Wavelength Range	λ <sub>c</sub>	840	850	860	nm	-
Extinction Ratio	EX	2			dB	2
Spectral width (RMS)	Δλ			0.6	nm	
Transmitter and Dispersion Penalty	TDP			4.3	dB	
Optical Return Loss Tolerance	ORLT			12	dB	
Eye Diagram	IEEE Std 802.3bm compatible					
<b>Receiver</b>						
Center Wavelength	λ <sub>c</sub>	840	850	860	nm	
Average Receiver Sensitivity (P <sub>avg</sub> )	S			-11	dBm	3
Average Receiver Sensitivity (P <sub>avg</sub> )	S			-7.5	dBm	4
Receiver Overload (P <sub>avg</sub> )	P <sub>OL</sub>	2.5			dBm	
Damage Threshold	P <sub>OL</sub>	3.4			dBm	
Optical Reflectance	ORL			-12	dB	
LOS Assert	LOS <sub>A</sub>	-30			dB	
LOS De-Assert	LOS <sub>D</sub>			-11.5	dB	
LOS Hysteresis		0.5			dB	

### Notes:

1. The optical power is launched into OM3 MMF.
2. Measured with a PRBS 2<sup>31</sup>-1 test pattern @25.78125Gbps.
3. Measured with a PRBS 2<sup>31</sup>-1 test pattern, 25.78125Gb/s, BER<5E<sup>-5</sup>.
4. Measured with PRBS 2<sup>31</sup>-1 test pattern, 25.78125Gb/s, BER<10<sup>-12</sup>.

## Pin Descriptions

Pin	Symbol	Function/Description	Notes
1	GND	Transmitter Ground (Common with Receiver Ground)	1
2	Tx2-	Transmitter Inverted Data Input	
3	Tx2+	Transmitter Non-Inverted Data output	
4	GND	Transmitter Ground (Common with Receiver Ground)	1
5	Tx4-	Transmitter Inverted Data Input	
6	Tx4+	Transmitter Non-Inverted Data output	
7	GND	Transmitter Ground (Common with Receiver Ground)	1
8	ModSelL	Module Select	2
9	ResetL	Module Reset	2
10	VccRx	3.3V Power Supply Receiver	
11	SCL	2-Wire serial Interface Clock	2
12	SDA	2-Wire serial Interface Data	2
13	GND	Transmitter Ground (Common with Receiver Ground)	1
14	Rx3+	Receiver Non-Inverted Data Output	
15	Rx3-	Receiver Inverted Data Output	
16	GND	Transmitter Ground (Common with Receiver Ground)	1
17	Rx1+	Receiver Non-Inverted Data Output	
18	Rx1-	Receiver Inverted Data Output	
19	GND	Transmitter Ground (Common with Receiver Ground)	1
20	GND	Transmitter Ground (Common with Receiver Ground)	1
21	Rx2-	Receiver Inverted Data Output	
22	Rx2+	Receiver Non-Inverted Data Output	
23	GND	Transmitter Ground (Common with Receiver Ground)	1
24	Rx4-	Receiver Inverted Data Output	1
25	Rx4+	Receiver Non-Inverted Data Output	
26	GND	Transmitter Ground (Common with Receiver Ground)	1
27	ModPrsl	Module Present	
28	IntL	Interrupt	2
29	VccTx	3.3V power supply transmitter	
30	Vcc1	3.3V power supply	
31	LPMODE	Low Power Mode	2
32	GND	Transmitter Ground (Common with Receiver Ground)	1
33	Tx3+	Transmitter Non-Inverted Data Input	
34	Tx3-	Transmitter Inverted Data Output	

35	GND	Transmitter Ground (Common with Receiver Ground)	1
36	Tx1+	Transmitter Non-Inverted Data Input	
37	Tx1-	Transmitter Inverted Data Output	
38	GND	Transmitter Ground (Common with Receiver Ground)	1

**Notes:**

1. The module signal grounds are isolated from the module case.
2. This is an open collector/drain output that on the host board requires a 4.7KΩ to 10KΩ pull-up resistor to VccHost.



**Recommended Host Board Power Supply Filter Network**



## Recommended Application Interface Block Diagram

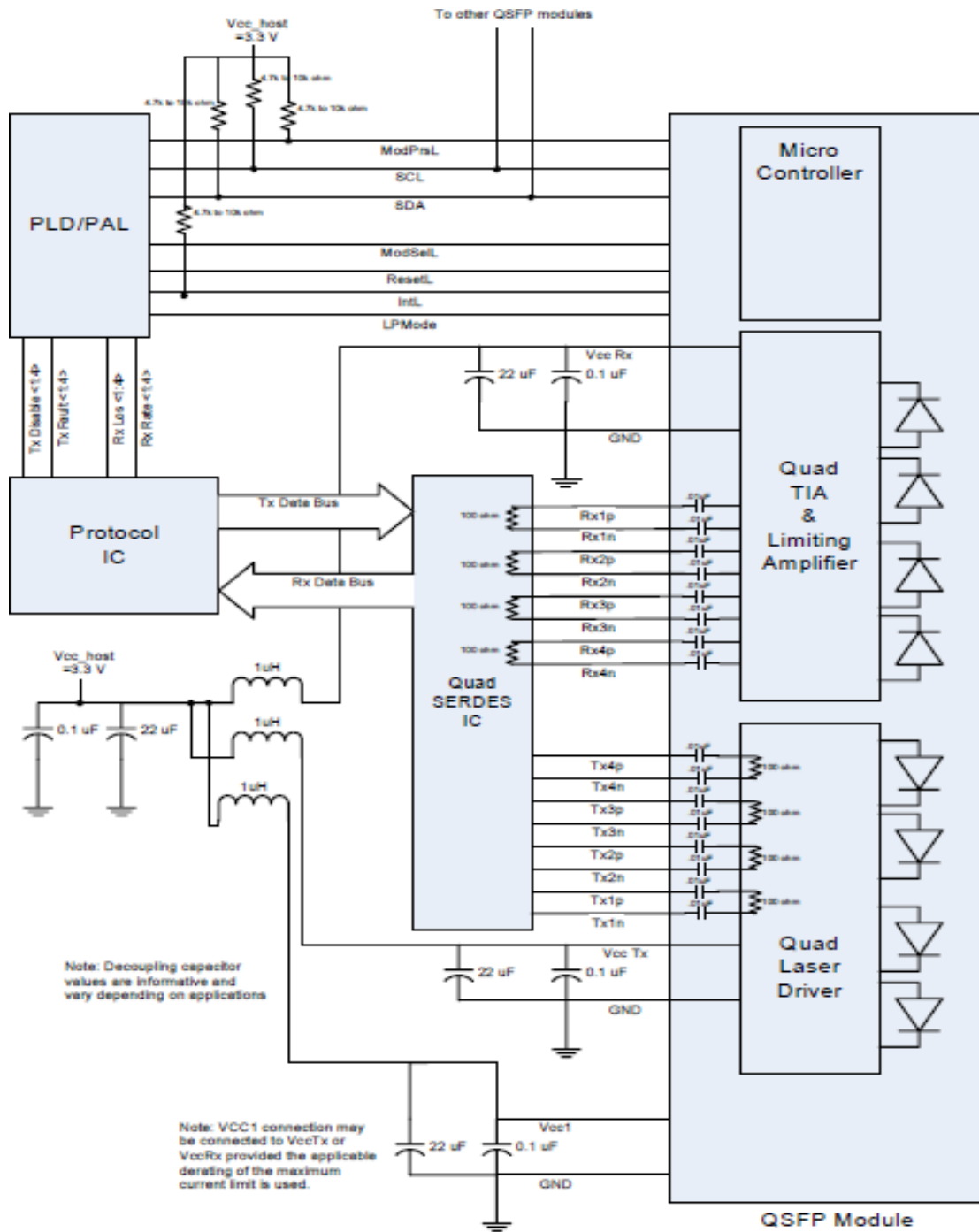

# Mechanical Specifications



**About Us:**

Proline Options is one of North America's leading providers of transceivers and high speed cabling. With a reputation for quality, tested products that cover the connectivity spectrum, Proline Options has a solution for you regardless of the specification.

At Proline Options, every product is tested in its intended application - never batch or spec tested only. We run bandwidth, distance and IOS network tests. We have documented an impressive 0.03% failure rate over the last 10 years. To continue this rate of success we invest millions annually in our own on-site testing lab.



Tel: 855.933.3223

Email: [sales@prolineoptions.com](mailto:sales@prolineoptions.com)

Email: [techsupport@prolineoptions.com](mailto:techsupport@prolineoptions.com)

Web: <https://www.prolineoptions.com>