

HCD25B15I0133-0-40-PRO

Fujitsu® HCD25B15I0133-0-40 Compatible TAA Compliant 25GBase-BX SFP28 Transceiver (SMF, 1310nmTx/1270nmRx, 40km, DOM, -40 to 85C, LC)

Features

- SFF-8402 and SFF-8472 Compliance
- Simplex LC Connector
- Industrial Temperature -40 to 85 Celsius
- Single-mode Fiber
- Hot Pluggable
- Excellent ESD Protection
- Metal with Lower EMI
- RoHS Compliant and Lead Free



Applications:

- 25GBase Ethernet
- Access and Enterprise

Product Description

This Fujitsu® HCD25B15I0133-0-40 compatible SFP28 transceiver provides 25GBase-BX throughput up to 40km over single-mode fiber (SMF) using a wavelength of 1310nmTx/1270nmRx via an LC connector. It is guaranteed to be 100% compatible with the equivalent Fujitsu® transceiver. This easy to install, hot swappable transceiver has been programmed, uniquely serialized and data-traffic and application tested to ensure that it will initialize and perform identically. Digital optical monitoring (DOM) support is also present to allow access to real-time operating parameters. This transceiver is Trade Agreements Act (TAA) compliant. We stand behind the quality of our products and proudly offer a limited lifetime warranty.

Proline's transceivers are RoHS compliant and lead-free.

TAA refers to the Trade Agreements Act (19 U.S.C. & 2501-2581), which is intended to foster fair and open international trade. TAA requires that the U.S. Government may acquire only "U.S. – made or designated country end products.



Regulatory Compliance

- ESD to the Electrical PINs: compatible with MIL-STD-883E Method 3015.4
- ESD to the LC Receptacle: compatible with IEC 61000-4-3
- EMI/EMC compatible with FCC Part 15 Subpart B Rules, EN55022:2010
- Laser Eye Safety compatible with FDA 21CFR, EN60950-1& EN (IEC) 60825-1,2
- RoHS compliant with EU RoHS 2.0 directive 2015/863/EU

Absolute Maximum Ratings

Parameter	Symbol	Min.	Typ.	Max.	Unit	Notes
Maximum Supply Voltage	Vcc	-0.3		4.0	V	
Storage Temperature	TS	-40		85	°C	
Operating Case Temperature	Tc	-40	25	85	°C	
Relative Humidity	RH	5		95	%	
Data Rate	BR		24.33 25.78		Gb/s	
Bit Error Rate	BER			5×10^{-5}		1
Supported Link Length on 9/125umSMF, 25.78Gb/s	L		40		km	2

Notes:

1. Tested with a PRBS $2^{31}-1$ test pattern for 25.78Gb/s operation.
2. Distances are based on FC-PI-6 Rev. 3.1 and IEEE 802.3 standards, with FEC.

Electrical Characteristics

Parameter	Symbol	Min.	Typ.	Max.	Unit	Notes	
Power Supply Voltage	VCC	3.135	3.3	3.465	V		
Module Supply Current	I _{cc}			450	mA		
Power Dissipation	PD			1500	mW		
Transmitter							
Input Differential Impedance	Z _{IN}		100		Ω		
Differential Data Input Swing	V _{IN} , P-P	180		700	mVP-P		
TX_FAULT	Transmitter Fault	VOH	2.0		VCCHOST	V	
	Normal Operation	VOL	0		0.8	V	
TX_DISABLE	Transmitter Disable	VIH	2.0		VCCHOST	V	
	Transmitter Enable	VIL	0		0.8	V	
Receiver							
Output Differential Impedance	Z _O		100		Ω		
Differential Data Output Swing	V _{OUT} , P-P	300		850	mVP-P	1	
Data Output Rise Time, Fall Time	t _r , t _f			15	ps	2	
RX_LOS	Loss of signal (LOS)	VOH	2.0		VCCHOST	V	3
	Normal Operation	VOL	0		0.8	V	3

Notes:

1. Internally AC coupled, but requires an external 100Ω differential load termination.
2. 20–80%.
3. LOS is an open collector output. Should be pulled up with 4.7kΩ on the host board.

Optical Characteristics

Parameter	Symbol	Min.	Typ.	Max.	Unit	Notes
Transmitter						
Launch Optical Power	Po	0		+5	dBm	1
Center Wavelength Range	λ_c	1260	1270	1280	nm	
Extinction Ratio	EX	3.5			dB	2
Spectral Width (-20dB)	$\Delta\lambda$			1	nm	
Side Mode Suppression Ratio	SMSR	30			dB	
Optical Rise/Fall Time @25.78Gb/s	tr/tf	15			ps	3
Optical Return Loss Tolerance	ORLT			12	dB	
Pout @TX-Disable Asserted	Poff			-30	dBm	1
Receiver						
Center Wavelength	λ_c	1300	1310	1320	nm	
Receiver OMA Sensitivity	RxSENS			-18	dBm	4
Receiver Overload (Pavg)	POL	-5			dBm	
Optical Return Loss	ORL	26			dB	
LOS De-Assert	LOSD			-19	dBm	
LOS Assert	LOSA	-35			dBm	
LOS Hysteresis		0.5			dB	

Notes:

1. Class 1 Laser Safety per FDA/CDRH and EN (IEC) 60825 regulations.
2. 20dB spectral width.
3. Unfiltered, 20-80%
4. Measured with PRBS $2^{31}-1$ at 5×10^{-5} BER.

Pin Descriptions

Pin	Symbol	Name/Descriptions	Notes
1	VeeT	Transmitter Ground	1
2	TX_Fault	Transmitter Fault (LVTTTL-O) - High indicates a fault condition	2
3	TX_Disable	Transmitter Disable (LVTTTL-I) – High or open disables the transmitter	3
4	SDA	Two wire serial interface Data Line (LVCMOS-I/O) (MOD-DEF2)	4
5	SCL	Two wire serial interface Clock Line (LVCMOS-I/O) (MOD-DEF1)	4
6	MOD_ABS	Module Absent (Output), connected to VeeT or VeeR in the module	5
7	RS0	NA	6
8	RX_LOS	Receiver Loss of Signal (LVTTTL-O)	2
9	RS1	NA	6
10	VeeR	Receiver Ground	1
11	VeeR	Receiver Ground	1
12	RD-	Inverse Received Data out (CML-O)	
13	RD+	Received Data out (CML-O)	
14	VeeR	Receiver Ground	1
15	VccR	Receiver Power - +3.3V	
16	VccT	Transmitter Power - +3.3 V	
17	VeeT	Transmitter Ground	1
18	TD+	Transmitter Data In (CML-I)	
19	TD-	Inverse Transmitter Data In (CML-I)	
20	VeeT	Transmitter Ground	1

Notes:

1. The module signal grounds are isolated from the module case.
2. This is an open collector/drain output that on the host board requires a 4.7K Ω to 10K Ω pull-up resistor to VccHost.
3. This input is internally biased high with a 4.7K Ω to 10K Ω pull-up resistor to VccT.
4. Two-Wire Serial interface clock and data lines require an external pull-up resistor dependent on the capacitance load.
5. This is a ground return that on the host board requires a 4.7K Ω to 10K Ω pull-up resistor to VccHost.
6. Rate select can also be set through the 2-wire bus in accordance with SFF-8472 v. 12.1, Rx Rate Select is set at Bit 3, Byte 110, Address A2h. Tx Rate Select is set at Bit 3, Byte 118, Address A2h.
Note: writing a “1” selects maximum bandwidth operation. Rate select is the logic OR of the input state of Rate Select Pin and 2-wire bus.

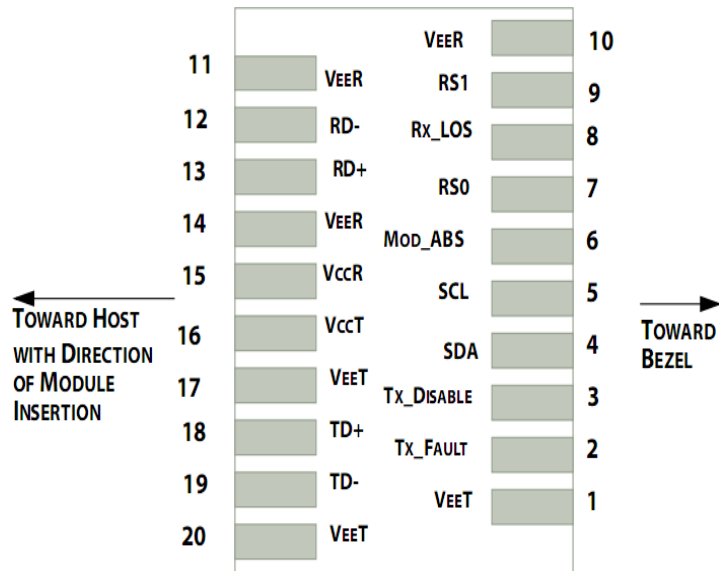

Pin-out of connector Block on Host board

Recommended Application Interface Block Diagram

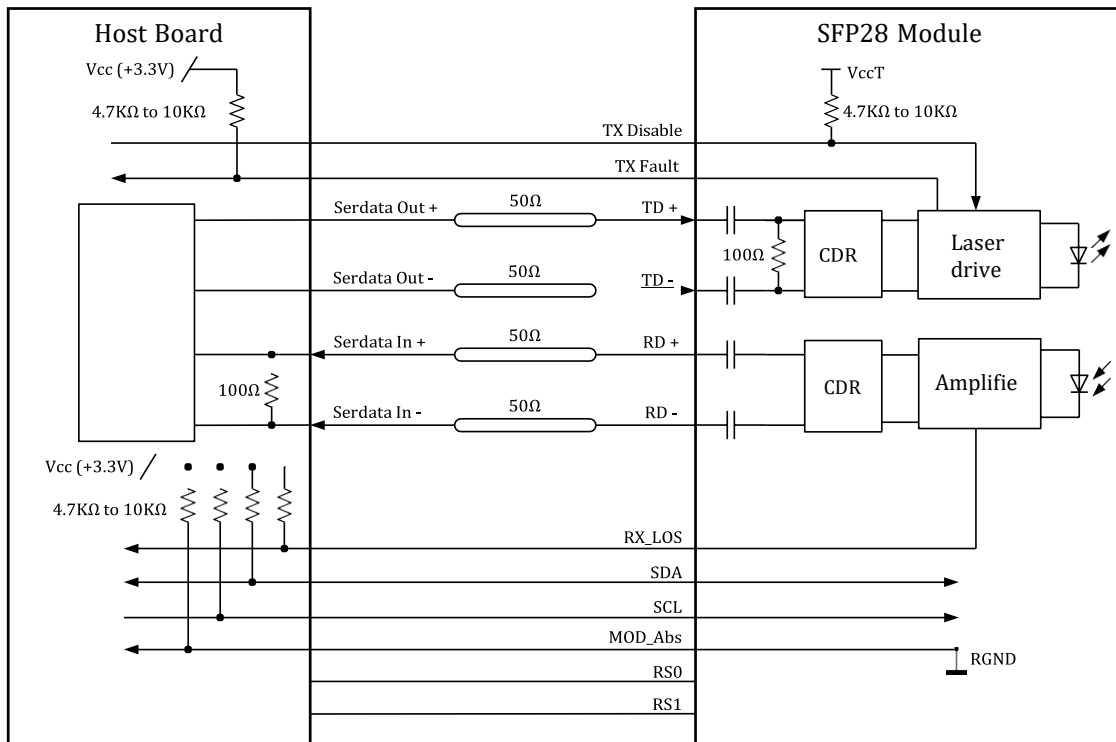

Mechanical Specifications

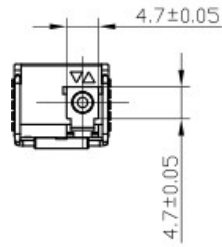

Unit:mm

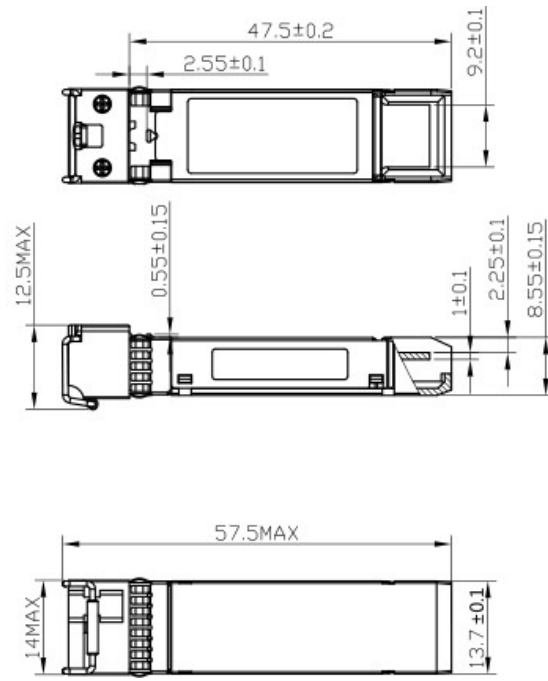

About Us:

Proline Options is one of North America's leading providers of transceivers and high speed cabling. With a reputation for quality, tested products that cover the connectivity spectrum, Proline Options has a solution for you regardless of the specification.

At Proline Options, every product is tested in its intended application - never batch or spec tested only. We run bandwidth, distance and IOS network tests. We have documented an impressive 0.03% failure rate over the last 10 years. To continue this rate of success we invest millions annually in our own on-site testing lab.



Tel: 855.933.3223

Email: sales@prolineoptions.com

Email: techsupport@prolineoptions.com

Web: <https://www.prolineoptions.com>