

FG-TRAN-QSFP+LR-PRO

Fortinet® FG-TRAN-QSFP+LR Compatible 40GBase-LR4 QSFP+ TAA Compliant Transceiver SMF, 1270nm to 1330nm, 10km, LC, DOM

Features

- SFF-8436 Compliance
- Duplex LC Connector
- Commercial Temperature 0 to 70 Celsius
- Single-mode Fiber
- Hot Pluggable
- Excellent ESD Protection
- Metal with Lower EMI
- RoHS Compliant and Lead Free



Applications:

- 40GBase Ethernet
- Access and Enterprise

Product Description

This Fortinet® FG-TRAN-QSFP+LR compatible QSFP+ transceiver provides 40GBase-LR4 throughput up to 10km over single-mode fiber (SMF) using a wavelength of 1270nm to 1330nm via an LC connector. It is guaranteed to be 100% compatible with the equivalent Fortinet® transceiver. This easy to install, hot swappable transceiver has been programmed, uniquely serialized and data-traffic and application tested to ensure that it will initialize and perform identically. Digital optical monitoring (DOM) support is also present to allow access to real-time operating parameters. This transceiver is Trade Agreements Act (TAA) compliant. We stand behind the quality of our products and proudly offer a limited lifetime warranty.

Proline's transceivers are RoHS compliant and lead-free.

TAA refers to the Trade Agreements Act (19 U.S.C. & 2501-2581), which is intended to foster fair and open international trade. TAA requires that the U.S. Government may acquire only "U.S. – made or designated country end products.



Regulatory Compliance

- ESD to the Electrical PINs: compatible with MIL-STD-883E Method 3015.4
- ESD to the LC Receptacle: compatible with IEC 61000-4-3
- EMI/EMC compatible with FCC Part 15 Subpart B Rules, EN55022:2010
- Laser Eye Safety compatible with FDA 21CFR, EN60950-1& EN (IEC) 60825-1,2
- RoHS compliant with EU RoHS 2.0 directive 2015/863/EU

Absolute Maximum Ratings

Parameter	Symbol	Min.	Typ.	Max.	Unit
Storage Temperature	TS	-40		85	°C
Relative Humidity	Rh	0		85	%
Supply Voltage	Vcc	-0.5		4.0	V

Recommended Operating Conditions

Parameter	Symbol	Min.	Typ.	Max.	Unit
Power Supply Voltage	Vcc	3.13	3.3	3.47	V
Power Supply Current	Icc			100	mA
Case Operating Temperature	Tc	-5		70	°C

Optical Characteristics

Parameter	Symbol	Min.	Typ.	Max.	Unit	Notes
Wavelength	L0	1264.5	1271	1277.5	nm	
	L1	1284.5	1291	1297.5	nm	
	L2	1304.5	1311	1317.5	nm	
	L3	1324.5	1331	1337.5	nm	
Transmitter						
Side-mode Suppression Ratio	SMSR	30			dB	
Total Average Launch Power	P_T			8.3	dBm	
Average Launch Power, each Lane		-7		2.3	dBm	
Optical Modulation Amplitude, each Lane	OMA	-4		3.5	dBm	
Difference in launch Power between any two lanes (OMA)				6.5	dB	
Launch Power in OMA minus Transmitter and Dispersion Penalty (TDP), each Lane		-4.8			dBm	
TDP, each Lane	TDP			2.3	dB	
Extinction Ratio	ER	3.5			dB	
Relative Intensity Noise	R_{in}			-128	dB/Hz	12dB reflection
Optical Return Loss Tolerance				20	dB	
Transmitter Reflectance	R_T			-12	dB	
Transmitter Eye Mask Definition X1, X2, X3, Y1, Y2, Y3		Specification Values 0.25, 0.4, 0.45, 0.25, 0.28, 0.4				
Average Launch Power OFF Transmitter, each Lane	P_{off}			-30	dBm	
Receiver						
Damage Threshold	TH_d	3.3			dBm	1
Average Power at receiver Input, each Lane		-13.7		2.3	dB	
Receiver Reflectance	R_R			-26	dB	
Receiver Power (OMA), each Lane				3.5	dBm	
Stressed Receiver Sensitivity in OMA, each Lane				-9.9	dBm	
Receiver Sensitivity, each Lane	S_R			-11.5	dBm	
Difference in Receive Power between any Lanes (OMA)				-7.5	dBm	
Condition of Stress Receiver Sensitivity Test						
Vertical Eye Closure Penalty, each Lane			1.6		dB	
Stressed Eye Jitter, each Lane			0.3		UI	

Notes:

1. The receiver shall be able to tolerate, without damage, continuous exposure to a modulated optical input signal having this power level on one lane. The receiver does not have to operate correctly at this input power.

Electrical Characteristics

Parameter	Symbol	Min.	Typ.	Max.	Unit	Notes
Power Consumption (XLPP1)				1.5	W	
Supply Current	ICC		0.75	1.0	A	
Control I/O Voltage, High	VIH	2.0		VCC	V	
Control I/O Voltage, Low	VIL	0		0.7	V	
Inter-Channel Skew	TSK			150	ps	
RESETL Duration			10		us	
RESETL De-assert time				100	ms	
Power on time				100	ms	
Transmitter						
Single Ended Output Voltage Tolerance		-0.3		4	V	
AC Common mode Voltage Tolerance (RMS)		15			mV	
Tx Input Diff Voltage	VI	90		1600	mV	
Tx Input Diff Impedance	ZIN	80	100	120	Ω	
Differential Input Return Loss	See IEEE 802.3ba 86A.4.11				dB	10MHz-11.1GHz
J2 Jitter tolerance	Jt2			0.18	UI	
J9 Jitter Tolerance	Jt9			0.26	UI	
Data Dependent Pulse Width Shrinkage	DDPWS			0.07	UI	
Eye Mask Coordinates: X1, X2, Y1, Y2	0.1, 0.31, 95, 350					
Receiver (XLPP1)						
Single Ended Output Voltage Tolerance		-0.3		4	V	Preferred to TP1 signal common
AC Common mode Voltage Tolerance (RMS)				7.5	mV	
Termination Mismatch at 1MHz				5	%	
Differential Output Return Loss	See IEEE 802.3ba 86A.4.2.1				dB	10MHz-11.1GHz
Common-mode Output Return Loss	See IEEE 802.3ba 86A.4.2.1				dB	10MHz-11.1GHz
Rx Output Diff Voltage	Vo		600	800	mV	
Rx Output Rise and Fall Time	Tr/Tf			35	ps	20% to 80%
J2 Jitter Tolerance	Jr2			0.46	UI	
J9 Jitter Tolerance	Jr9			0.63	UI	
Eye Mask Coordinates: X1, X2, Y1, Y2	0.29, 0.5, 150, 425				UI, mV	

Notes:

1. The single ended input voltage tolerance is the allowable range of the instantaneous input signals

Pin Descriptions

Pin	Logic	Symbol	Name/Descriptions	Ref.
1		GND	Module Ground	1
2	CML-I	Tx2-	Transmitter inverted data input	
3	CML-I	Tx2+	Transmitter non-inverted data input	
4		GND	Module Ground	1
5	CML-I	Tx4-	Transmitter inverted data input	
6	CML-I	Tx4+	Transmitter non-inverted data input	
7		GND	Module Ground	1
8	LVTTTL-I	MODSEIL	Module Select	2
9	LVTTTL-I	ResetL	Module Reset	2
10		VCCRx	+3.3v Receiver Power Supply	
11	LVCNOS-I	SCL	2-wire Serial interface clock	2
12	LVCNOS-I/O	SDA	2-wire Serial interface data	2
13		GND	Module Ground	1
14	CML-O	RX3+	Receiver non-inverted data output	
15	CML-O	RX3-	Receiver inverted data output	
16		GND	Module Ground	1
17	CML-O	RX1+	Receiver non-inverted data output	
18	CML-O	RX1-	Receiver inverted data output	
19		GND	Module Ground	1
20		GND	Module Ground	1
21	CML-O	RX2-	Receiver inverted data output	
22	CML-O	RX2+	Receiver non-inverted data output	
23		GND	Module Ground	1
24	CML-O	RX4-	Receiver inverted data output	
25	CML-O	RX4+	Receiver non-inverted data output	
26		GND	Module Ground	1
27	LVTTTL-O	ModPrsL	Module Present, internal pulled down to GND	
28	LVTTTL-O	IntL	Interrupt output should be pulled up on host board	2
29		VCCTx	+3.3v Transmitter Power Supply	
30		VCC1	+3.3v Power Supply	
31	LVTTTL-I	LPMode	Low Power Mode	2
32		GND	Module Ground	1
33	CML-I	Tx3+	Transmitter non-inverted data input	
34	CML-I	Tx3-	Transmitter inverted data input	
35		GND	Module Ground	1
36	CML-I	Tx1+	Transmitter non-inverted data input	
37	CML-I	Tx1-	Transmitter inverted data input	
38		GND	Module Ground	1

Notes:

1. Module circuit ground is isolated from module chassis ground with in the module.
2. Open collector; should be pulled up with 4.7k-10k ohms on host board to a voltage between 3.15V and 3.6V.

Electrical Pin-out Details

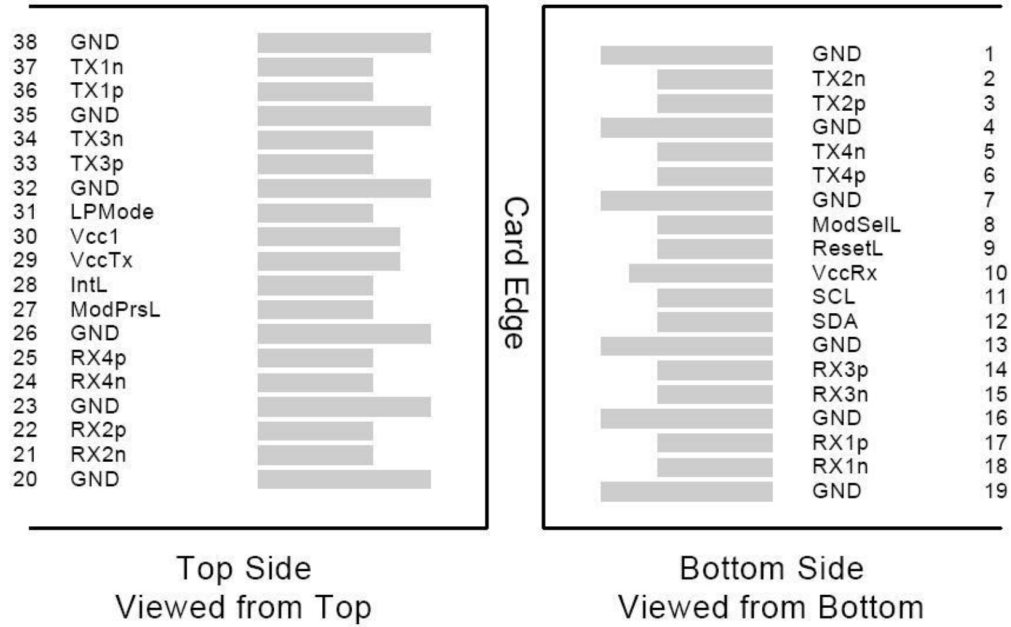

Recommended Circuit Schematic

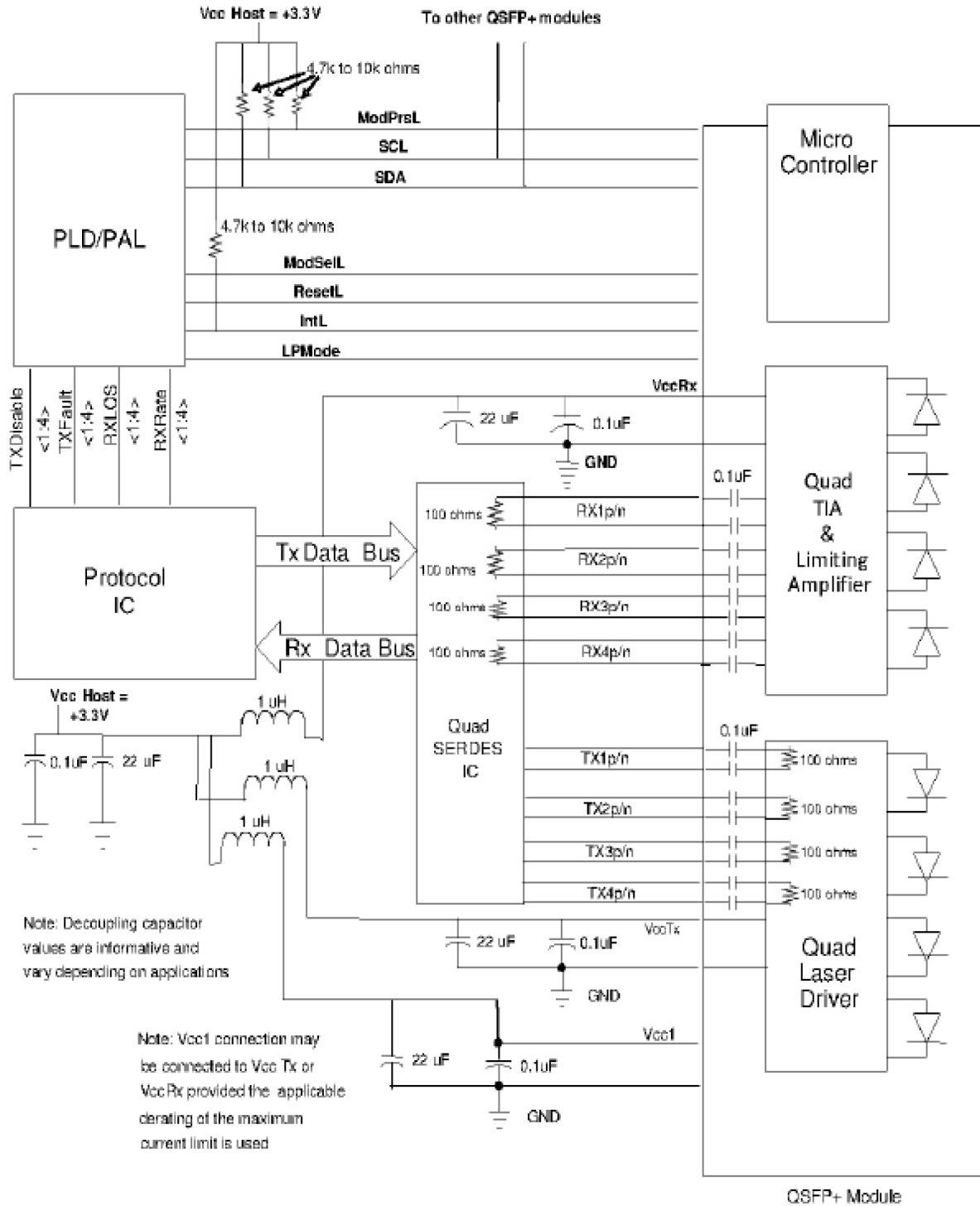

EEPROM Information

2-Wire Serial Address: 1010000x

0	ID and status	(3 Bytes)
2		
21	Interrupt Flags	(19 Bytes)
33	Module Monitors	(12 Bytes)
81	Channel Monitors	(48 Bytes)
85	Reserved	(4 Bytes)
97	Control	(12 Bytes)
99	Reserved	(2 Bytes)
106	Free Side Device and Channel Mask	(7 Bytes)
107	Reserved	(1 Bytes)
111	Free Side Device Properties	(4 Bytes)
118	Reserved	(7 Bytes)
122	Password Change Entry Area (Optional)	(4 Bytes)
126	Password Entry Area (Optional)	(4 Bytes)
127	Page Select Byte	(1 Bytes)

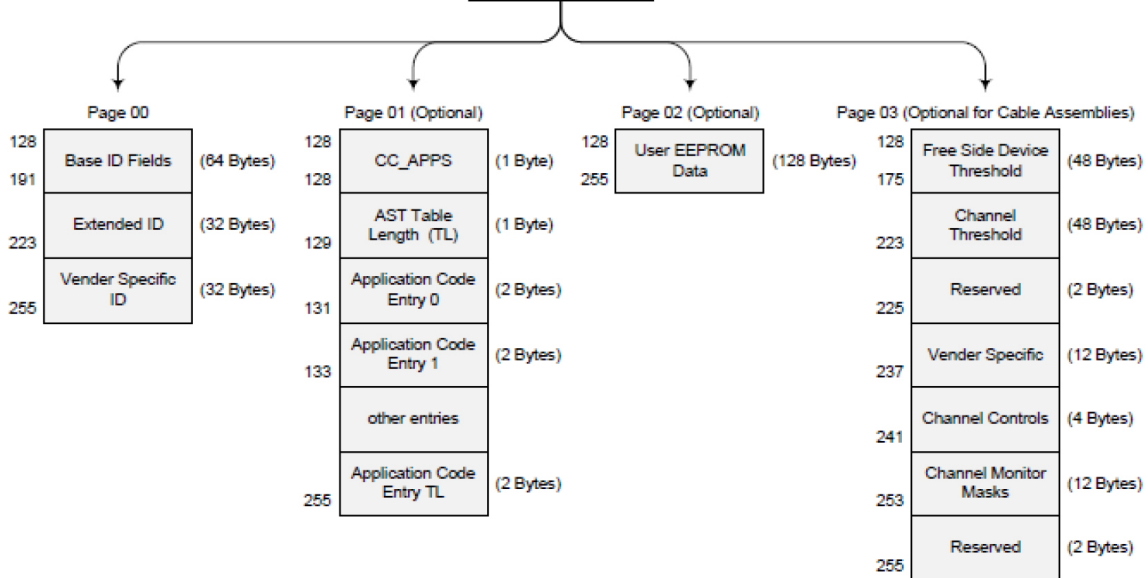

Mechanical Specifications

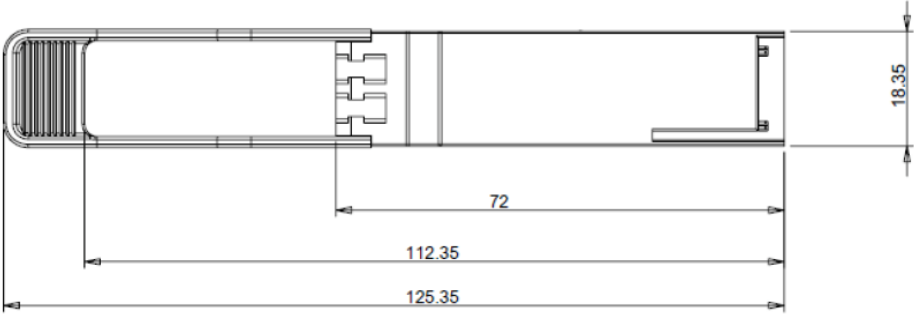
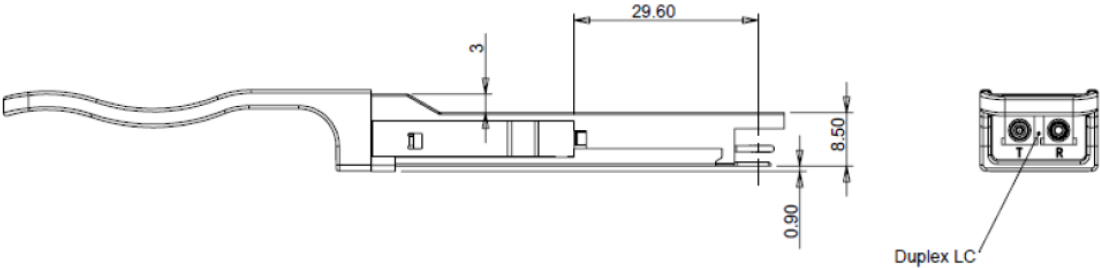

About Us:

Proline Options is one of North America's leading providers of transceivers and high speed cabling. With a reputation for quality, tested products that cover the connectivity spectrum, Proline Options has a solution for you regardless of the specification.

At Proline Options, every product is tested in its intended application - never batch or spec tested only. We run bandwidth, distance and IOS network tests. We have documented an impressive 0.03% failure rate over the last 10 years. To continue this rate of success we invest millions annually in our own on-site testing lab.

Tel: 855.933.3223

Email: sales@prolineoptions.com

Email: techsupport@prolineoptions.com

Web: <https://www.prolineoptions.com>