

CAB-Q-2Q-100G-3M-PRO

Arista Networks® CAB-Q-2Q-100G-3M Compatible TAA 100GBase-CU QSFP28 to 2xQSFP28 Direct Attach Cable (Passive Twinax, 3m, 30AWG)

Features

- QSFP Module Complaint to SFF-8661
- Enable (4x25.78)100Gbps Transmission
- Transmission Data Rate up to 25.78 Gbps per Channel
- Operating Temperature: 0 to 70 Celcius
- RoHS Complaint and Lead-Free
- Built in EEPROM Functions



Applications:

- Switch, Storage, Server

Product Description

This is a Arista Networks® CAB-Q-2Q-100G-3M Compatible 100GBase-CU QSFP28 to 2xQSFP28 direct attach cable that operates over passive copper with a maximum reach of 3m. It has been programmed, uniquely serialized, and data-traffic and application tested to ensure it is 100% compliant and functional. We stand behind the quality of our products and proudly offer a limited lifetime warranty. This cable is TAA (Trade Agreements Act) compliant and is built to comply with MSA (Multi-Source Agreement) standards.

Proline’s transceivers are RoHS compliant and lead-free.

TAA refers to the Trade Agreements Act (19 U.S.C. & 2501-2581), which is intended to foster fair and open international trade. TAA requires that the U.S. Government may acquire only “U.S. – made or designated country end products.



General Specifications

Parameter	Symbol	Min.	Typ.	Max.	Unit
Supply Voltage	Vcc	3.13	3.3	3.47	V
Storage Temperature	Tstg	-40		85	°C
Operating Temperature	Tc	0		70	°C
Relative Humidity	RH	5		85	%
Data Rate			100		Gbps

Electrical Specifications

Parameter	Symbol	Min.	Typ.	Max.	Unit
Resistance	Rcon			3	Ω
Insulation Resistance	Rins			10	MΩ
Raw Cable Impedance	Zca	95	100	105	Ω
Mated Connector Impedance	Zmated	85	100	115	Ω
Insertions Loss at 12.89 GHz	SDD21	8		22.48	dB
Return Loss at 12.89GHz	SDD11/22	Return_Loss(f)≥	$\left\{ \begin{array}{ll} 16.5-2\sqrt{f} & 0.5 \leq f < 4.1 \\ 10.66-14\log_{10}(f/5.5) & 4.1 \leq f \leq 19 \end{array} \right\}$		dB
Differential to Common-Mode Return Loss	SCD11/22	Return_Loss(f)≥	$\left\{ \begin{array}{ll} 22-(20/25.78)f & 0.01 \leq f \leq 12.89 \\ 15-(6/25.78)f & 12.89 \leq f \leq 19 \end{array} \right\}$		dB
Differential to Common-Mode Conversion Loss	SCD21-SDD21	Conversion_Loss(f)≥ -IL(f)≥	$\left\{ \begin{array}{ll} 10 & 0.01 \leq f < 12.89 \\ 27-(29/22)f & 0.01 \leq f < 15.7 \\ 6.3 & 15.7 \leq f \leq 19 \end{array} \right\}$		dB
Minimum COM	COM	3			dB

Pin Descriptions

Pin	Logic	Symbol	Name/Descriptions	Plug Sequence	Ref.
1		GND	Module Ground.	1	1
2	CML-I	Tx2-	Transmitter Inverted Data Input.	3	
3	CML-I	Tx2+	Transmitter Non-Inverted Data Input.	3	
4		GND	Module Ground.	1	1
5	CML-I	Tx4-	Transmitter Inverted Data Input.	3	
6	CML-I	Tx4+	Transmitter Non-Inverted Data Input.	3	
7		GND	Module Ground.	1	1
8	LVTTTL-I	MODSEIL	Module Select.	3	2
9	LVTTTL-I	ResetL	Module Reset.	3	2
10		VccRx	+3.3V Receiver Power Supply.	2	
11	LVC MOS-I/O	SCL	2-Wire Serial Interface Clock.	3	2
12	LVC MOS-I/O	SDA	2-Wire Serial Interface Data.	3	2
13		GND	Module Ground.	1	1
14	CML-O	Rx3+	Receiver Non-Inverted Data Output.	3	
15	CML-O	Rx3-	Receiver Inverted Data Output.	3	
16		GND	Module Ground.	1	1
17	CML-O	Rx1+	Receiver Non-Inverted Data Output.	3	
18	CML-O	Rx1-	Receiver Inverted Data Output.	3	
19		GND	Module Ground.	1	1
20		GND	Module Ground.	3	1
21	CML-O	Rx2-	Receiver Inverted Data Output.	3	
22	CML-O	Rx2+	Receiver Non-Inverted Data Output.	1	
23		GND	Module Ground.	1	1
24	CML-O	Rx4-	Receiver Inverted Data Output.	3	
25	CML-O	Rx4+	Receiver Non-Inverted Data Output.	3	
26		GND	Module Ground.	1	1
27	LVTTTL-O	ModPrsL	Module Present. Internally pulled down to the GND.	3	
28	LVTTTL-O	IntL	Interrupt output should be pulled up on the host board.	3	2
29		VccTx	+3.3V Transmitter Power Supply.	2	
30		Vcc1	+3.3V Power Supply.	2	
31	LVTTTL-I	LPMode	Low-Power Mode.	3	2
32		GND	Module Ground.	1	1
33	CML-I	Tx3+	Transmitter Non-Inverted Data Input.	3	
34	CML-I	Tx3-	Transmitter Inverted Data Input.	3	
35		GND	Module Ground.	1	1
36	CML-I	Tx1+	Transmitter Non-Inverted Data Input.	3	
37	CML-I	Tx1-	Transmitter Inverted Data Input.	3	
38		GND	Module Ground.	1	1

Notes:

1. GND is the symbol for signal and supply (power) common for the QSFP+ module. All are common within the QSFP+ module and all module voltages are references to this potential unless otherwise noted. Connect the directly to the host board signal-common ground plane.
2. VccRx, Vcc1, and VccTx are the receiver and transmitter power supplies and shall be applied concurrently. Requirements defined for the host board power supply filtering is shown in host board figure. VccRx, Vcc1, and VccTx may be internally connected within the QSFP+ module in any combination. The connector pins are each for a maximum current of 500mA.

Electrical Pin-out Details

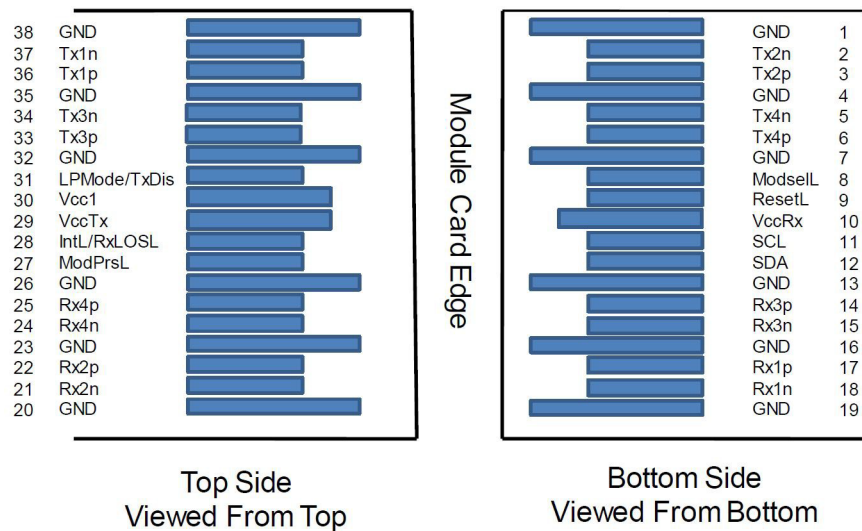

Wire Diagram

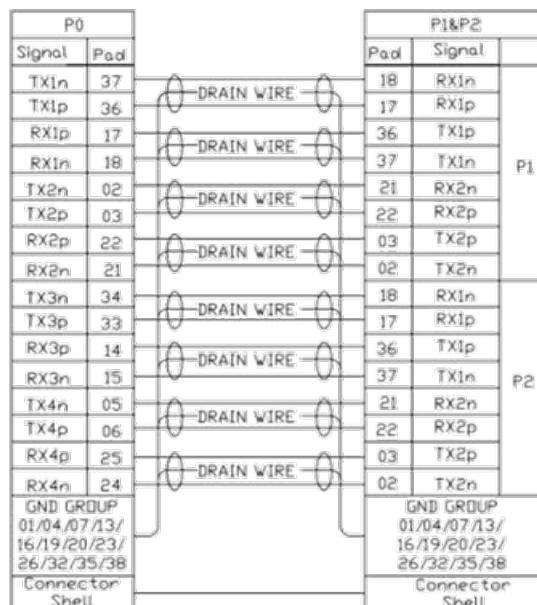

Mechanical Specifications

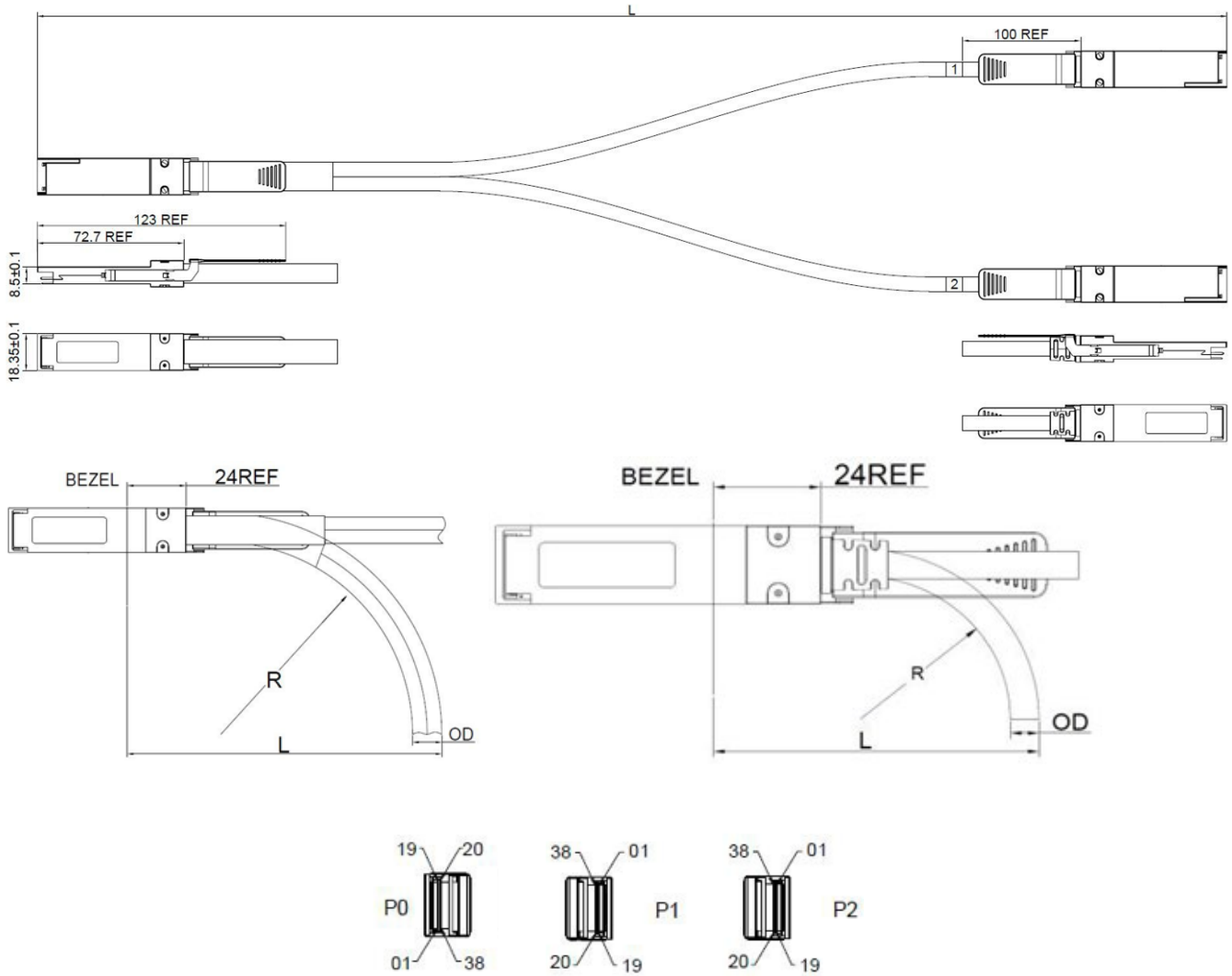

Cable Specifications

Parameter	Symbol	Min.	Typ.	Max.	Unit
Length	L	0.5		5.0	M
AWG			30		AWG
Jacket Material		PVC, Black (or Customization)			
OD	P0		12MM		
	P1 & P2		6MM		
Bend Radius	P0	R	60MM		
	P1 & P2		30MM		
Minimum Bend Radius	P0	L	96MM		
	P1 & P2		60MM		

About Us:

Proline Options is one of North America's leading providers of transceivers and high speed cabling. With a reputation for quality, tested products that cover the connectivity spectrum, Proline Options has a solution for you regardless of the specification.

At Proline Options, every product is tested in its intended application - never batch or spec tested only. We run bandwidth, distance and IOS network tests. We have documented an impressive 0.03% failure rate over the last 10 years. To continue this rate of success we invest millions annually in our own on-site testing lab.



Tel: 855.933.3223

Email: sales@prolineoptions.com

Email: techsupport@prolineoptions.com

Web: <https://www.prolineoptions.com>