

### 430-4917-PRO

Dell® 430-4917 Compatible TAA Compliant 40GBase-LR4 QSFP+ Transceiver (SMF, 1270nm to 1330nm, 10km, DOM, 0 to 70C, LC)

#### Features

- SFF-8436 Compliance
- Duplex LC Connector
- Commercial Temperature 0 to 70 Celsius
- Single-mode Fiber
- Hot Pluggable
- Excellent ESD Protection
- Metal with Lower EMI
- RoHS Compliant and Lead Free



#### Applications:

- 40GBase Ethernet
- Access and Enterprise

#### Product Description

This Dell® 430-4917 compatible QSFP+ transceiver provides 40GBase-LR4 throughput up to 10km over single-mode fiber (SMF) using a wavelength of 1270nm to 1330nm via an LC connector. It is guaranteed to be 100% compatible with the equivalent Dell® transceiver. This easy to install, hot swappable transceiver has been programmed, uniquely serialized and data-traffic and application tested to ensure that it will initialize and perform identically. Digital optical monitoring (DOM) support is also present to allow access to real-time operating parameters. This transceiver is Trade Agreements Act (TAA) compliant. We stand behind the quality of our products and proudly offer a limited lifetime warranty.

Proline's transceivers are RoHS compliant and lead-free.

TAA refers to the Trade Agreements Act (19 U.S.C. & 2501-2581), which is intended to foster fair and open international trade. TAA requires that the U.S. Government may acquire only "U.S. – made or designated country end products.



## Absolute Maximum Ratings

Parameter	Symbol	Min.	Typ.	Max.	Unit
Storage Temperature	TS	-40		85	°C
Relative Humidity	Rh	0		85	%
Supply Voltage	Vcc	-0.5		4.0	V
Case Operating Temperature	Tc	0		70	°C

## Electrical Characteristics

Parameter	Symbol	Min.	Typ.	Max.	Unit	Notes
Power Supply Voltage	Vcc	3.13	3.3	3.47	V	
Power Consumption				3.5	W	
Supply Current	ICC		0.75	1.0	A	
Control I/O Voltage, High	VIH	2.0		VCC	V	
Control I/O Voltage, Low	VIL	0		0.7	V	
Inter-Channel Skew	TSK			150	ps	
RESETL Duration			10		us	
RESETL De-assert time				100	ms	
Power on time				100	ms	
<b>Transmitter</b>						
Single Ended Output Voltage Tolerance		-0.3		4	V	
AC Common mode Voltage Tolerance (RMS)		15			mV	
Tx Input Diff Voltage	VI	90		1600	mV	
Tx Input Diff Impedance	ZIN	80	100	120	Ω	
Differential Input Return Loss	See IEEE 802.3ba 86A.4.11				dB	10MHz-11.1GHz
J2 Jitter tolerance	Jt2			0.18	UI	
J9 Jitter Tolerance	Jt9			0.26	UI	
Data Dependent Pulse Width Shrinkage	DDPWS			0.07	UI	
Eye Mask Coordinates: X1, X2, Y1, Y2	0.1, 0.31, 95, 350					
<b>Receiver</b>						
Single Ended Output Voltage Tolerance		-0.3		4	V	Preferred to TP1 signal common
AC Common mode Voltage Tolerance (RMS)				7.5	mV	
Termination Mismatch at 1MHz				5	%	
Differential Output Return Loss	See IEEE 802.3ba 86A.4.2.1				dB	10MHz-11.1GHz
Common-mode Output Return Loss	See IEEE 802.3ba 86A.4.2.1				dB	10MHz-11.1GHz
Rx Output Diff Voltage	Vo		600	800	mV	
Rx Output Rise and Fall Time	Tr/Tf			35	ps	20% to 80%
J2 Jitter Tolerance	Jr2			0.46	UI	
J9 Jitter Tolerance	Jr9			0.63	UI	
Eye Mask Coordinates: X1, X2, Y1, Y2	0.29, 0.5, 150, 425				UI, mV	

**Notes:**

1. The single ended input voltage tolerance is the allowable range of the instantaneous input signals

**Optical Characteristics**

Parameter	Symbol	Min.	Typ.	Max.	Unit	Notes
Wavelength	L0	1264.5	1271	1277.5	nm	
	L1	1284.5	1291	1297.5	nm	
	L2	1304.5	1311	1317.5	nm	
	L3	1324.5	1331	1337.5	nm	
<b>Transmitter</b>						
Side-mode Suppression Ratio	SMSR	30			dB	
Total Average Launch Power	$P_T$			8.3	dBm	
Average Launch Power, each Lane		-7		2.3	dBm	
Optical Modulation Amplitude, each Lane	OMA	-4		3.5	dBm	
Difference in launch Power between any two lanes (OMA)				6.5	dB	
Launch Power in OMA minus Transmitter and Dispersion Penalty (TDP), each Lane		-4.8			dBm	
TDP, each Lane	TDP			2.3	dB	
Extinction Ratio	ER	3.5			dB	
Relative Intensity Noise	$R_{in}$			-128	dB/Hz	12dB reflection
Optical Return Loss Tolerance				20	dB	
Transmitter Reflectance	$R_T$			-12	dB	
Transmitter Eye Mask Definition X1, X2, X3, Y1, Y2, Y3	Specification Values 0.25, 0.4, 0.45, 0.25, 0.28, 0.4					
Average Launch Power OFF Transmitter, each Lane	$P_{off}$			-30	dBm	
<b>Receiver</b>						
Damage Threshold	$TH_d$	3.3			dBm	1
Average Power at receiver Input, each Lane		-13.7		2.3	dB	
Receiver Reflectance	$R_R$			-26	dB	
Receiver Power (OMA), each Lane				3.5	dBm	
Stressed Receiver Sensitivity in OMA, each Lane				-9.9	dBm	
Receiver Sensitivity, each Lane	$S_R$			-11.5	dBm	
Difference in Receive Power between any Lanes (OMA)				-7.5	dBm	
<b>Condition of Stress Receiver Sensitivity Test</b>						
Vertical Eye Closure Penalty, each Lane			1.6		dB	
Stressed Eye Jitter, each Lane			0.3		UI	

**Notes:**

1. The receiver shall be able to tolerate, without damage, continuous exposure to a modulated optical input signal having this power level on one lane. The receiver does not have to operate correctly at this input power.

## Pin Descriptions

Pin	Logic	Symbol	Name/Descriptions	Ref.
1		GND	Module Ground	1
2	CML-I	Tx2-	Transmitter inverted data input	
3	CML-I	Tx2+	Transmitter non-inverted data input	
4		GND	Module Ground	1
5	CML-I	Tx4-	Transmitter inverted data input	
6	CML-I	Tx4+	Transmitter non-inverted data input	
7		GND	Module Ground	1
8	LVTTTL-I	MODSEIL	Module Select	2
9	LVTTTL-I	ResetL	Module Reset	2
10		VCCRx	+3.3v Receiver Power Supply	
11	LVC MOS-I	SCL	2-wire Serial interface clock	2
12	LVC MOS-I/O	SDA	2-wire Serial interface data	2
13		GND	Module Ground	1
14	CML-O	RX3+	Receiver non-inverted data output	
15	CML-O	RX3-	Receiver inverted data output	
16		GND	Module Ground	1
17	CML-O	RX1+	Receiver non-inverted data output	
18	CML-O	RX1-	Receiver inverted data output	
19		GND	Module Ground	1
20		GND	Module Ground	1
21	CML-O	RX2-	Receiver inverted data output	
22	CML-O	RX2+	Receiver non-inverted data output	
23		GND	Module Ground	1
24	CML-O	RX4-	Receiver inverted data output	
25	CML-O	RX4+	Receiver non-inverted data output	
26		GND	Module Ground	1
27	LVTTTL-O	ModPrsL	Module Present, internal pulled down to GND	
28	LVTTTL-O	IntL	Interrupt output should be pulled up on host board	2
29		VCCTx	+3.3v Transmitter Power Supply	
30		VCC1	+3.3v Power Supply	
31	LVTTTL-I	LPMode	Low Power Mode	2
32		GND	Module Ground	1
33	CML-I	Tx3+	Transmitter non-inverted data input	
34	CML-I	Tx3-	Transmitter inverted data input	
35		GND	Module Ground	1
36	CML-I	Tx1+	Transmitter non-inverted data input	
37	CML-I	Tx1-	Transmitter inverted data input	
38		GND	Module Ground	1

**Notes:**

1. Module circuit ground is isolated from module chassis ground with in the module.
2. Open collector; should be pulled up with 4.7k-10k ohms on host board to a voltage between 3.15V and 3.6V.

**Electrical Pin-out Details**

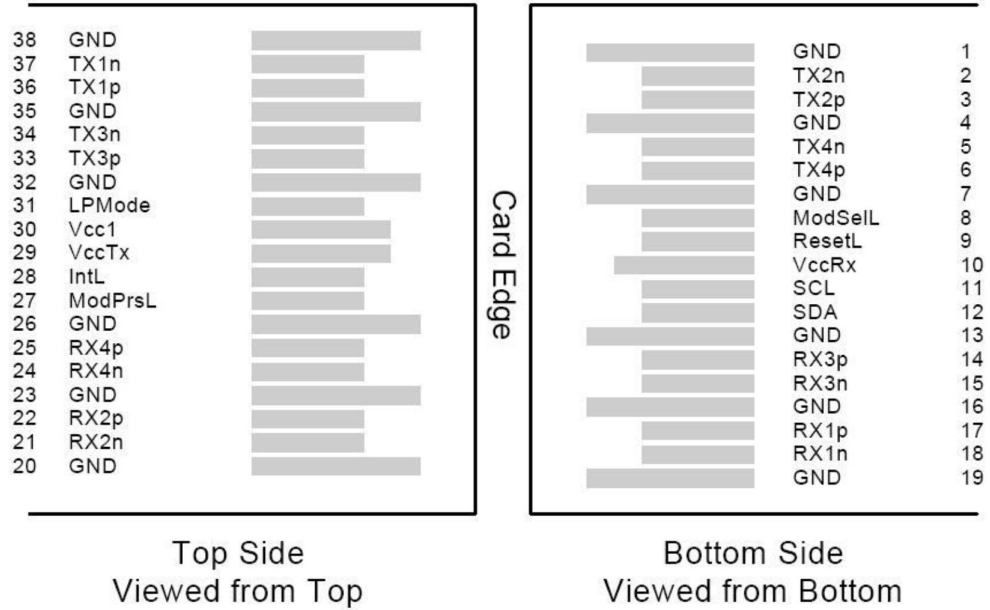

# Recommended Circuit Schematic

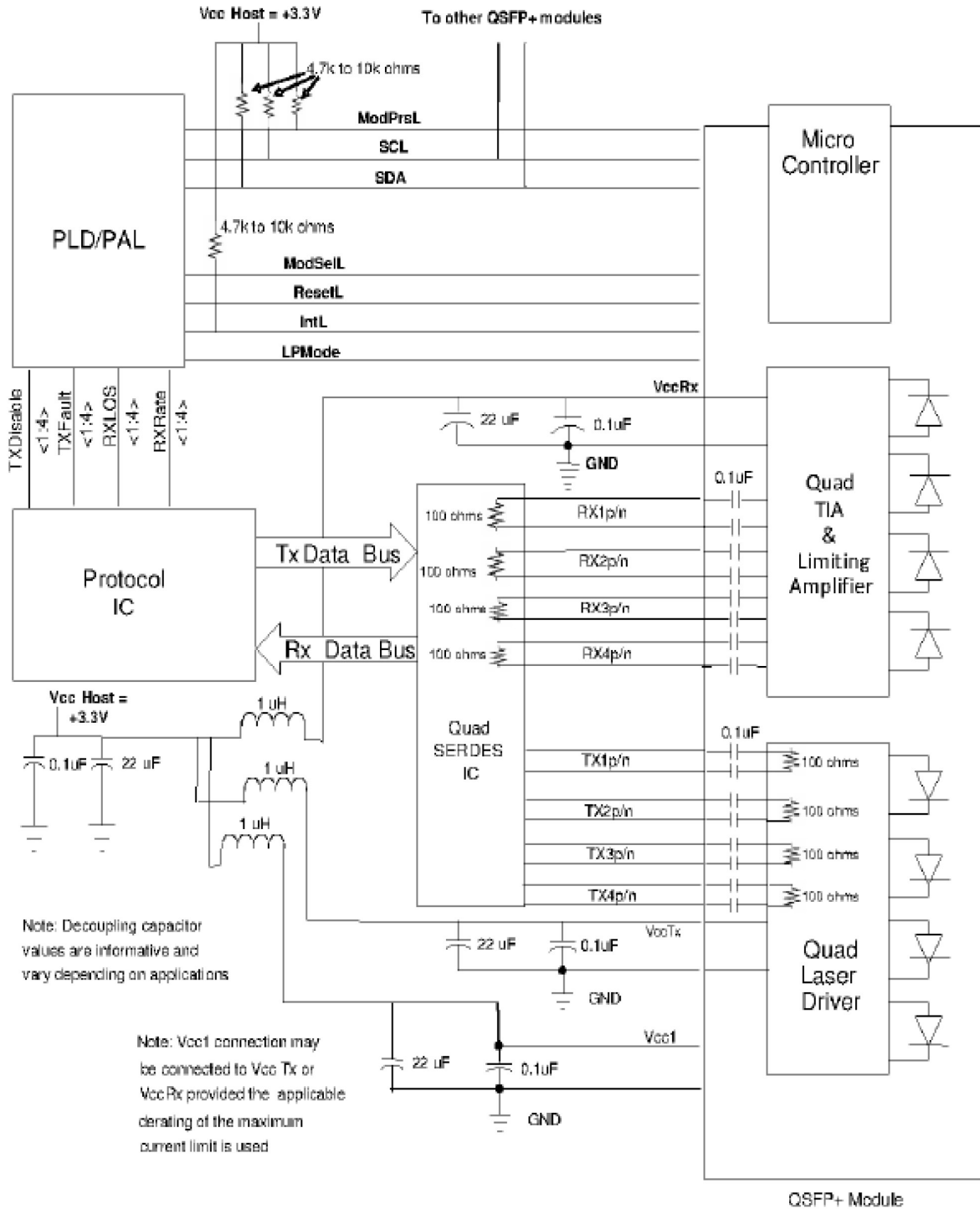

# EEPROM Information

2-Wire Serial Address: 1010000x

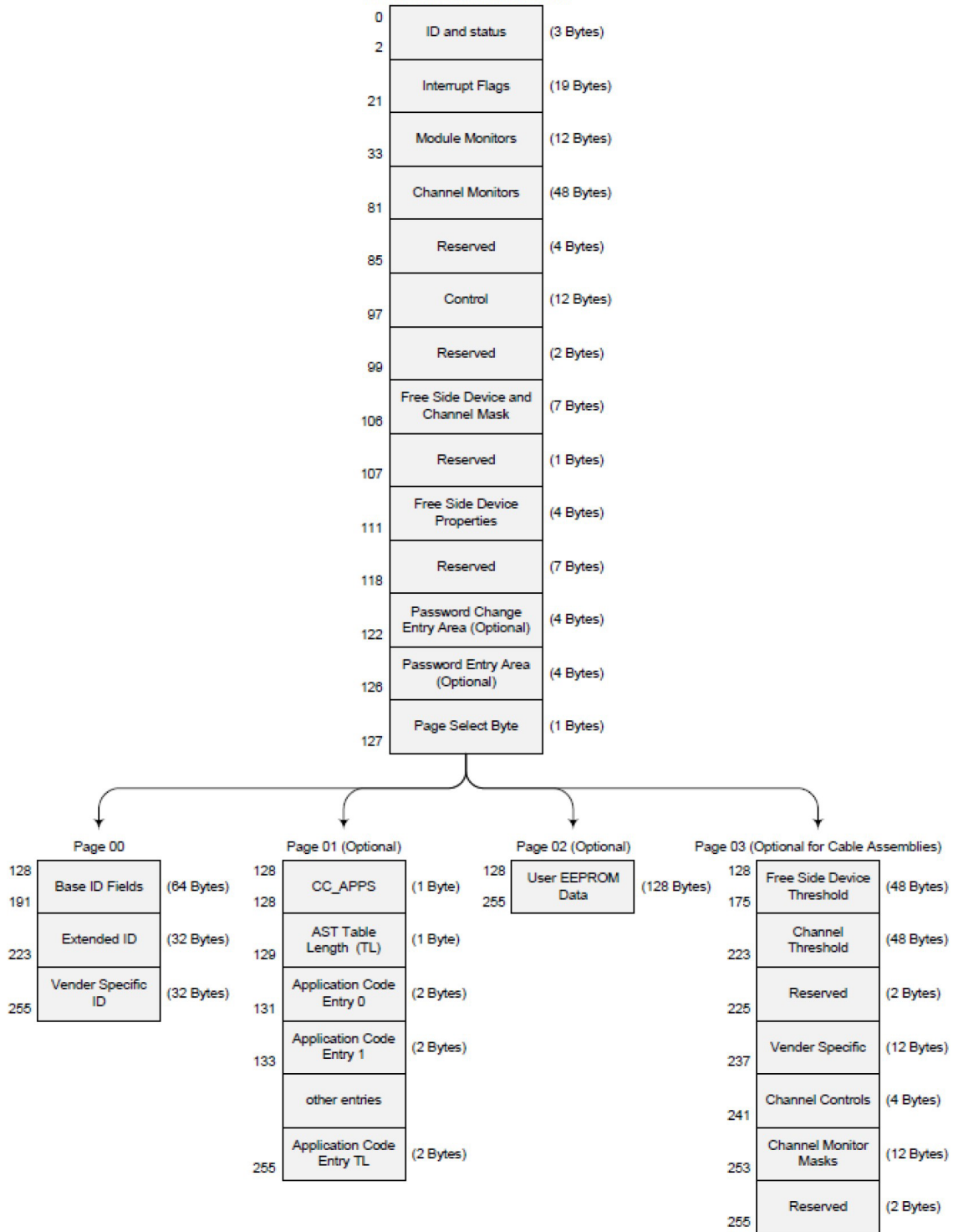

**Mechanical Specifications**





**About Us:**

Proline Options is one of North America's leading providers of transceivers and high speed cabling. With a reputation for quality, tested products that cover the connectivity spectrum, Proline Options has a solution for you regardless of the specification.

At Proline Options, every product is tested in its intended application - never batch or spec tested only. We run bandwidth, distance and IOS network tests. We have documented an impressive 0.03% failure rate over the last 10 years. To continue this rate of success we invest millions annually in our own on-site testing lab.



Tel: 855.933.3223

Email: [sales@prolineoptions.com](mailto:sales@prolineoptions.com)

Email: [techsupport@prolineoptions.com](mailto:techsupport@prolineoptions.com)

Web: <https://www.prolineoptions.com>