

33030100160-PRO

ZTE® Compatible TAA Compliant 2.4Gbs/1.2Gbs-C+ SFP Transceiver (SMF, 1490nmTx/1310nmRx, 25km, DOM, 0 to 70C, SC)

Features

- INF-8074 and SFF-8472 Compliance
- Simplex SC Connector
- Commercial Temperature 0 to 70 Celsius
- Single-mode Fiber
- Hot Pluggable
- Excellent ESD Protection
- Metal with Lower EMI
- RoHS Compliant and Lead Free



Applications:

- GPON
- Access and Enterprise

Product Description

This ZTE® SFP transceiver provides 2.4Gbs/1.2Gbs-C+ throughput up to 25km over single-mode fiber (SMF) using a wavelength of 1490nmTx/1310nmRx via a SC connector. It is guaranteed to be 100% compatible with the equivalent ZTE® transceiver. This easy to install, hot swappable transceiver has been programmed, uniquely serialized and data-traffic and application tested to ensure that it will initialize and perform identically. Digital optical monitoring (DOM) support is also present to allow access to real-time operating parameters. This transceiver is Trade Agreements Act (TAA) compliant. We stand behind the quality of our products and proudly offer a limited lifetime warranty.

Proline's transceivers are RoHS compliant and lead-free.

TAA refers to the Trade Agreements Act (19 U.S.C. & 2501-2581), which is intended to foster fair and open international trade. TAA requires that the U.S. Government may acquire only "U.S. – made or designated country end products.



Absolute Maximum Ratings

Parameter	Symbol	Min.	Typ.	Max.	Unit	Notes
Maximum Supply Voltage	V _{cc}	-0.5		4.0	V	1
Storage Temperature	T _{sto}	-40		85	°C	2
Operating Case Temperature	T _{op}	0		70	°C	
Data Rate	DR		2488/1244		Mb/s	3
Bit Error Rate	BER			10 ⁻¹⁰		

Notes:

1. For electrical power interface
2. Ambient temperature
3. Downstream/Upstream

Electrical Characteristics (V_{cc}=3.14V to 3.46V, T_c=-40°C to 85°C)

Parameter	Symbol	Min.	Typ.	Max.	Unit	Notes
Input Voltage	V _{cc}	3.14	3.30	3.46	V	
Power Supply Current	I _{cc}		200	300	mA	
Differential data input swing	V _{in,pp}	600		1600	mV	
Input differential impedance	R _{in}		100		Ω	
Differential data output swing	V _{out, pp}	400		1600	mV	
Input Signal Level (LVTTTL H)	V	2.0		V _{CC}	V	
Input Signal Level (LVTTTL L)	V	0		0.8		
Output Signal Level (LVTTTL H)	V	2.4		V _{CC}	V	
Output Signal Level (LVTTTL L)	V	0		0.4	V	

Optical Characteristics ($V_{CC}=3.14V$ to $3.46V$, $T_c=-40^{\circ}C$ to $85^{\circ}C$)

Parameter	Symbol	Min.	Typ.	Max.	Unit	Notes
Transmitter						
Transmitter Type	1490nm DFB Laser with Isolator					1
Downstream Signaling Speed	STX		2488		Mb/s	
Output Optical Power	PTX	3		7	dBm	2
Optical Output with TX OFF	Pout_off			-40	dBm	
Optical Extinction Ratio	ER	8.2			dB	
Optical Center Wavelength	λ_c	1480		1500	nm	
Spectral Width (-20dB)	$\Delta\lambda$			1	nm	
Side Mode Suppression Ratio	SMSR	30			dB	
Output Eye	Compliant with G.984. 2			Data Rate=2488Mb/s		
Receiver						
Receiver Type	1310nm APD/TIA burst-mode Receiver					
Signaling Speed	Srx		1244		MB/s	
Optical Center Wavelength	λ_c	1280	1310	1360	Nm	
Average Rx Sensitivity @1244Mb/s	Rx_sen			-30	dBm	3
Burst Sensitivity Receiver Overload	Pmax	-12			dBm	
Receiver Burst Mode Dynamic Range		15			dB	
LOS Assert	LOS_A	-45			dBm	
LOS De-Assert	LOS_D			-32	dBm	
LOS Hysteresis	LOS_H	0.5				

Notes:

1. Continuous-mode
2. Class 1 Product
3. @BER 10^{-10} PRBS $2^{23}-1$

Pin Descriptions

Pin	Symbol	Name/Descriptions	Ref.
1	VEET	Transmitter ground (common with receiver ground)	1
2	TFAULT	Transmitter Fault.	
3	TDIS	Transmitter Disable. Laser output disabled on high or open	2
4	MOD_DEF (2)	Module Definition 2. Data line for serial ID	3
5	MOD_DEF (1)	Module Definition 1. Clock line for serial ID	3
6	MOD_DEF (0)	Module Definition 0. Grounded within the module	3
7	RESET	Receiver Reset	4
8	BPD	Burst Packet Detect	5
9	RSSI Trigger	RSSI Trigger Signal From Host	6
10	VEER	Receiver ground (common with transmitter ground)	1
11	VEER	Receiver ground (common with transmitter ground)	1
12	RD-	Receiver Inverted DATA out. AC coupled	
13	RD+	Receiver Non-inverted DATA out. AC coupled	
14	VEER	Receiver ground (common with transmitter ground)	1
15	VCCR	Receiver power supply	
16	VCCT	Transmitter power supply	
17	VEET	Transmitter ground (common with receiver ground)	1
18	TD+	Transmitter Non-Inverted DATA in. AC coupled	
19	TD-	Transmitter Inverted DATA in. AC coupled	
20	VEET	Transmitter ground (common with receiver ground)	1

Notes:

1. Circuit ground is isolated from chassis ground
2. Disabled: $T_{DIS} > 2V$ or open, Enabled: $T_{DIS} < 0.8V$
3. Should Be pulled up with 4.7k – 10k ohm on host board to a voltage between 2V and 3.6V
4. Reset is a LVTTTL input which is used to clear receiver status before receiving the next burst packet
5. BPD is a LVTTTL output. High Level indicates that burst packet is detected by the receiver
6. RSSI Trigger is a LVTTTL input from host for starting ADC of digital RSSI circuit to sample the analog RSSI signal

Electrical Pad Layout

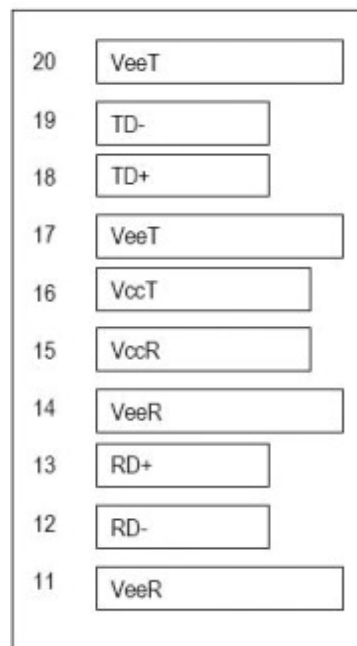
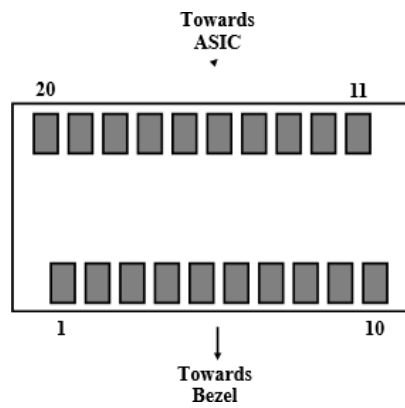

Top of Board

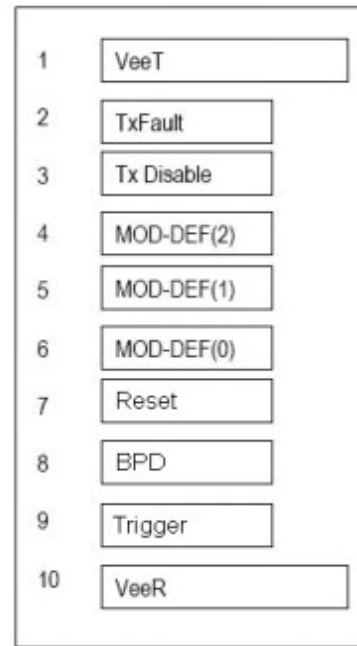

Bottom of Board (as viewed
thru top of board)

Digital Diagnostic Functions

This transceiver supports the 2-wire serial communication protocol as defined in the SFP MSA. Digital diagnostic information is accessible over the 2-wire interface at the address 0xA2. Digital diagnostics for this module are internally calibrated by default. A micro controller unit inside the transceiver gathers the monitoring information and reports the status of transceiver.

Transceiver Temperature, internally measured, represented as a 16 bit signed twos complement value in increments of 1/256 degrees Celsius, Temperature accuracy is better than ± 3 degrees Celsius over specified operating temperature and voltage.

Transceiver Supply Power, internally measured, represented as a 16 bit unsigned integer with the voltage defined as the full 16 bit value (0 – 65535) with LSB equal to 100 μ Volt, yielding a total range of 0 to +6.55 Volts.

Transceiver TX bias current, internally measured, represented as a 16 bit unsigned integer with the current defined as the full 16 bit value (0 – 65535) with LSB equal to 2 μ A, yielding a total range of 0 to 131mA. Accuracy is better than $\pm 10\%$ over specified operating temperature and voltage.

Transceiver TX output power, internally measured, represented as a 16 bit unsigned integer with the power defined as the full 16 bit value (0 – 65535) with LSB equal to 0.1 μ W. Data is assumed to be based on measurement of laser monitor photodiode current. Accuracy is better than ± 3 dB over specified temperature and voltage. Data is not valid when the transmitter is disabled.

Transceiver RX received optical power, internally measured, represented as a 16 bit unsigned integer with the power defined as the full 16 bit 35 value (0 – 65535) with LSB equal to 0.1 μ W. Accuracy is better than ± 3 dB over specified temperature and voltage.

Mechanical Specifications

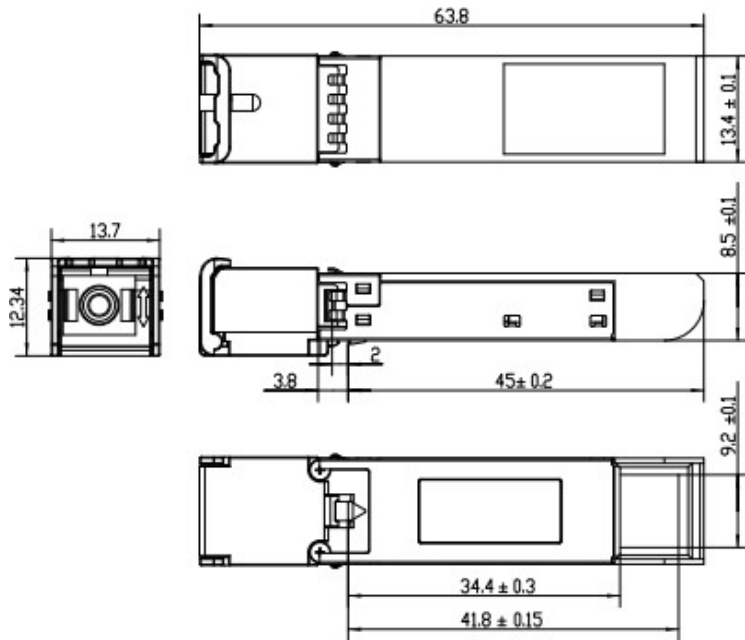

unit:millimeter

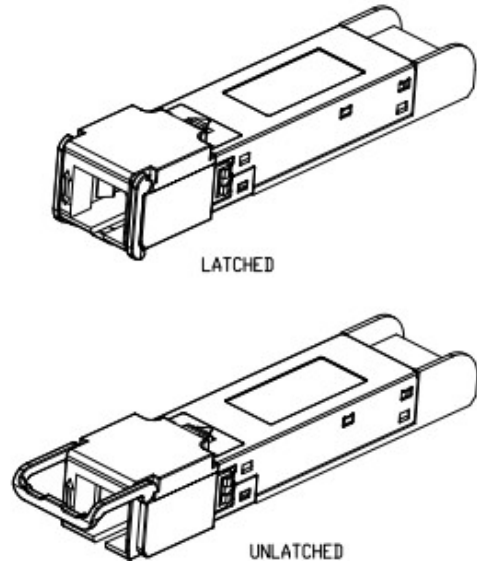

ALL DIMENSIONS ARE ±0.2mm UNLESS OTHERWISE SPECIFIED UNIT: mm

About Us:

Proline Options is one of North America's leading providers of transceivers and high speed cabling. With a reputation for quality, tested products that cover the connectivity spectrum, Proline Options has a solution for you regardless of the specification.

At Proline Options, every product is tested in its intended application - never batch or spec tested only. We run bandwidth, distance and IOS network tests. We have documented an impressive 0.03% failure rate over the last 10 years. To continue this rate of success we invest millions annually in our own on-site testing lab.



Tel: 855.933.3223

Email: sales@prolineoptions.com

Email: techsupport@prolineoptions.com

Web: <https://www.prolineoptions.com>