

1AB373120002-PRO

Alcatel-Lucent Nokia® 1AB373120002 Compatible TAA Compliant 1000Base-CWDM SFP Transceiver (SMF, 1510nm, 150km, 0 to 70C, LC)

Features

- INF-8074 and SFF-8472 Compliance
- Duplex LC Connector
- Commercial Temperature 0 to 70 Celsius
- Single-mode Fiber
- Hot Pluggable
- Excellent ESD Protection
- Metal with Lower EMI
- RoHS Compliant and Lead Free



Applications:

- 1000Base-SX Ethernet
- 1x Fibre Channel
- Access, Metro and Enterprise

Product Description

This Alcatel-Lucent Nokia® 1AB373120002 compatible SFP transceiver provides 1000Base-CWDM throughput up to 150km over single-mode fiber (SMF) using a wavelength of 1510nm via an LC connector. It is guaranteed to be 100% compatible with the equivalent Alcatel-Lucent Nokia® transceiver. This easy to install, hot swappable transceiver has been programmed, uniquely serialized and data-traffic and application tested to ensure that it will initialize and perform identically. It is built to meet or exceed the specifications of Alcatel-Lucent Nokia®, as well as to comply with MSA (Multi-Source Agreement) standards to ensure seamless network integration. This transceiver is Trade Agreements Act (TAA) compliant. We stand behind the quality of our products and proudly offer a limited lifetime warranty.

Proline's transceivers are RoHS compliant and lead-free.

TAA refers to the Trade Agreements Act (19 U.S.C. & 2501-2581), which is intended to foster fair and open international trade. TAA requires that the U.S. Government may acquire only "U.S. – made or designated country end products.



Regulatory Compliance

- ESD to the Electrical PINs: compatible with MIL-STD-883E Method 3015.4.
- ESD to the LC Receptacle: compatible with IEC 61000-4-3.
- EMI/EMC: compatible with FCC Part 15 Subpart B Rules, EN55022:2010.
- Laser Eye Safety: compatible with FDA 21CFR, EN60950-1& EN (IEC) 60825-1, 2.
- RoHS: compliant with EU RoHS 2.0 directive 2015/863/EU.

Absolute Maximum Ratings

Parameter	Symbol	Min.	Typ.	Max.	Unit	Notes
Maximum Supply Voltage	Vcc	-0.5		4.0	V	
Storage Temperature	Tstg	-40		85	°C	
Operating Case Temperature	Tc	0	25	70	°C	
Relative Humidity	RH	5		95	%	
Data Rate			1.25 1.0625		Gbps	

Electrical Characteristics

Parameter	Symbol	Min.	Typ.	Max.	Unit	Notes
Power Supply Voltage	Vcc	3.135	3.3	3.465	V	
Power Supply Current	Icc			300	mA	
Power Dissipation	P _{Diss}			1000	mW	
Transmitter Differential Input Voltage (TD +/-)		300		2200	mVp-p	1
Receiver Differential Output Voltage (RD +/-)		600		1200	mVp-p	2
Low-Speed Output: Transmitter Fault(Tx_Fault)/ Loss of Signal (LOS)	VOH	2.0		Vcc	V	3
	VOL	0		0.8	V	
Low-Speed Input: Transmitter Disable (Tx_Disable), MOD_DEF 1, MOD_DEF 2	VIH	2.0		Vcc	V	4
	VIL	0		0.8	V	

Notes:

1. Internally AC coupled and terminated to 100Ω differential load.
2. Internally AC coupled bit requires a 100Ω differential termination or internal to Serializer/Deserializer.
3. Pulled up externally with a 4.7KΩ-10KΩ resistor on the host board to VccT/R.
4. MOD_DEF1 and MOD_Def2 must be pulled up externally with a 4.7KΩ-10KΩ resistor on the host board Vcct,r.

Optical Characteristics

Parameter	Symbol	Min.	Typ.	Max.	Unit	Notes
Transmitter						
Launch Optical Power	Pavg	2		7	dBm	
Center Wavelength Range	λ_C	$\lambda-6.5$	λ	$\lambda+6.5$	nm	1
Extinction Ratio	EX	9			dB	
Spectral Width (-20dB)	$\Delta\lambda$			1	nm	
Side Mode Suppression Ratio	SMSR	30			dB	
Total Jitter	TJ			266	ps	
Dispersion Penalty				2	dB	
Optical Rise/Fall Time	Tr/Tf			260	ps	
Pout @TX-Disable Asserted	Pout			-45	dBm	
Eye Diagram	IEEE Std 802.3-2005 Gigabit Ethernet 1000Base-LX compatible					
Receiver						
Receiver Sensitivity	S			-34	dBm	2
Receiver Overload		-9			dBm	
Optical Return Loss	ORL	27			dB	
LOS De-Assert	LOSD			-35	dBm	
LOS Assert	LOSA	-45			dBm	
LOS Hysteresis		0.5	3	5	dB	
Tx_Disable assert time	T_off			10	Us	
Tx_Disable negate time	T_on			1	ms	
Time to Initialize (Includes Reset of TX_FAULT)	T_init			300	ms	
TX_Fault from Fault to Assertion	T_fault			100	us	
Tx_Disable Time to Start Reset	T_reset	10			us	
Receiver LOS Assert Time (On to Off)	T_D,RX_LOS			80	us	
Receiver LOS Assert Time (Off to On)	T_A,RX_LOS			80	us	
Serial 12C Clock Rate	I2C_Clock			100	kHz	

Notes:

1. The CWDM Transmitter Center Wavelengths " λ " are: 1270, 1290, 1310, 1330, 1350, 1370, 1390, 1410, 1430, 1450, 1470, 1490, 1510, 1530, 1550, 1570, 1590 and 1610nm. 1270 to 1450nm are named herein as O-band wavelength and 1470 to 1610nm as L-band wavelength generally.
2. Measured with PRBS 2⁷-1 test pattern, 1.25Gb/s, EX=9dB, BER<10⁻¹².

Pin Descriptions

Pin	Symbol	Name/Descriptions	Engagement Order (Insertion)	Ref.
1	VeeT	Transmitter Ground.	1	1
2	TX Fault	Transmitter Fault Indication.	3	1
3	TX Disable	Transmitter Disable. Module disables on “high or open.”	3	2
4	MOD-DEF2	Module Definition 2. 2-Wire Serial ID Interface.	3	3
5	MOD-DEF1	Module Definition 1. 2-Wire Serial ID Interface.	3	3
6	MOD-DEF0	Module Definition 0. Grounded in module.	3	3
7	Rate Select	Not Connected.	3	
8	LOS	Loss of Signal.	3	4
9	VeeR	Receiver Ground.	1	
10	VeeR	Receiver Ground.	1	
11	VeeR	Receiver Ground.	1	
12	RD-	Inverse Received Data out.	3	5
13	RD+	Received Data out.	3	5
14	VeeR	Receiver Ground.	1	
15	VccR	Receiver Power - +3.3V±5%	2	6
16	VccT	Transmitter Power - +3.3 V±5%	2	6
17	VeeT	Transmitter Ground.	1	
18	TD+	Transmitter Data In.	3	7
19	TD-	Inverse Transmitter Data In.	3	7
20	VeeT	Transmitter Ground.	1	

Notes:

1. Tx_Fault is open collector/drain output which should be pulled up externally with a 4.7KΩ-10KΩ resistor on the host board to supply $V_{ccT} + 0.3V$ or $V_{ccR} + 0.3V$. When “high,” this output indicates a laser fault of some kind. “Low” indicates normal operation. In the “low” state, the output will be pulled to <math>< 0.8V</math>.
2. Tx_Disable input is used to shut down the laser output per the state table below. It is pulled up within the module with a 4.7KΩ-10KΩ resistor.

Low (0 – 0.8V):	Transmitter on
Between (0.8V and 2V):	Undefined
High (2.0 – VccT):	Transmitter Disabled
Open:	Transmitter Disabled

3. MOD_Def0, 1, 2. These are the module definition pins. They should be pulled up with a 4.7KΩ-10KΩ resistor on the host board to supply less than $V_{ccT} + 0.3V$ or $V_{ccR} + 0.3V$.

Mod-Def0 is grounded by the module to indicate that the module is present.

Mod_Def1 is clock line of the 2-wire serial interface for optional serial ID.

Mod_Def2 is data line of two wire serial interface for optional serial ID.

4. LOS (Loss of signal) is an open collector/drain output which should be pulled up externally with a 4.7K Ω -10K Ω resistor on the host board to supply $<V_{ccT}+0.3V$ or $V_{ccR}+0.3V$. When "high," this output indicates the received optical power is below the worst case receiver sensitivity (as defined by the standard in use). "Low" indicates normal operation. In the "low" state, the output will be pulled to $<0.8V$.
5. RD-/+ : These are the differential receiver outputs. They are AC coupled 100 Ω differential lines which should be terminated with 100 Ω differential at the user SERDES. The AC coupling is done inside the module and thus not required on the host board.
6. VccR and VccT are the receiver and transmitter power supplies. They are defined as 3.3V \pm 5% at the SFP connector pin. The in-rush current will typically be no more than 30mA above steady state supply current after 500ns.
7. TD-/+ : These are the differential transmitter inputs. They are AC coupled differential lines with 100 Ω differential termination inside the module. The AC coupling is done inside the module and is thus not required on host board.

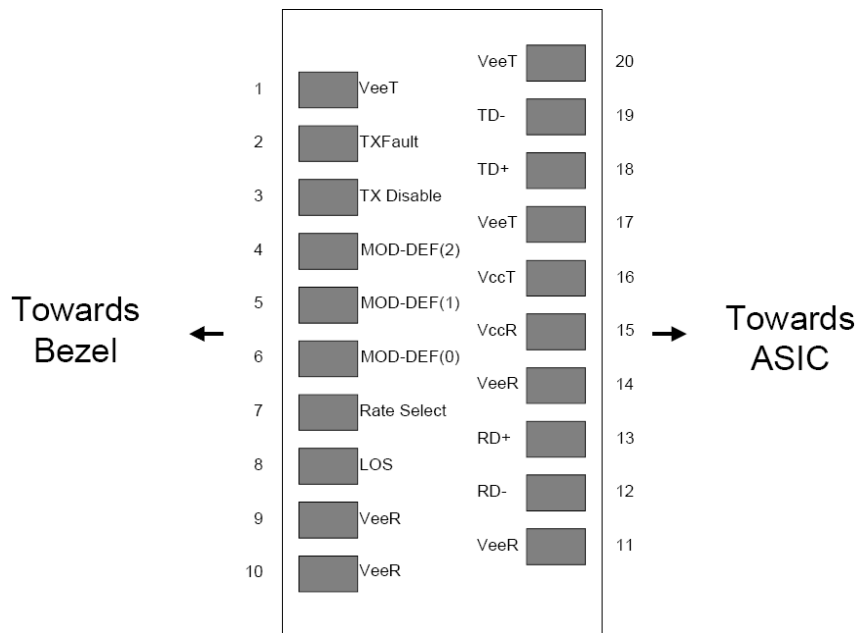

Pin-Out of Connector Block on the Host Board

Digital Diagnostic Memory Map

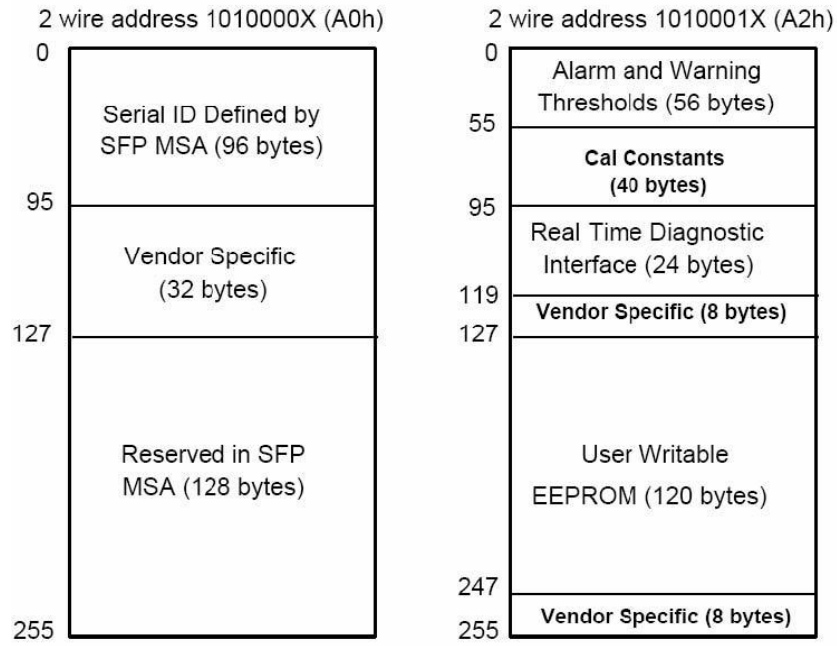

Recommended Host Board Power Supply

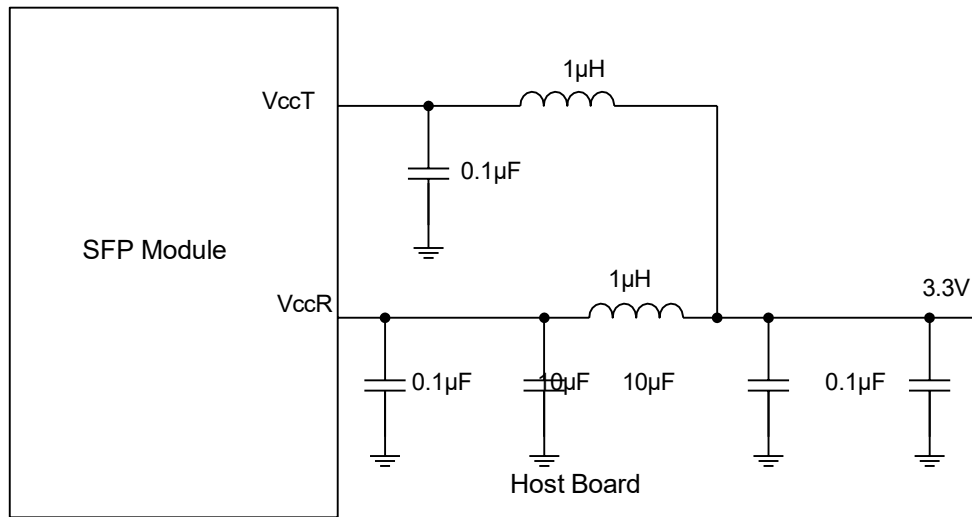

Mechanical Specifications

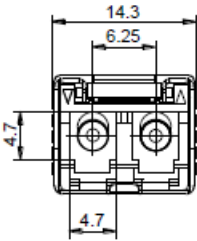

Unit:mm

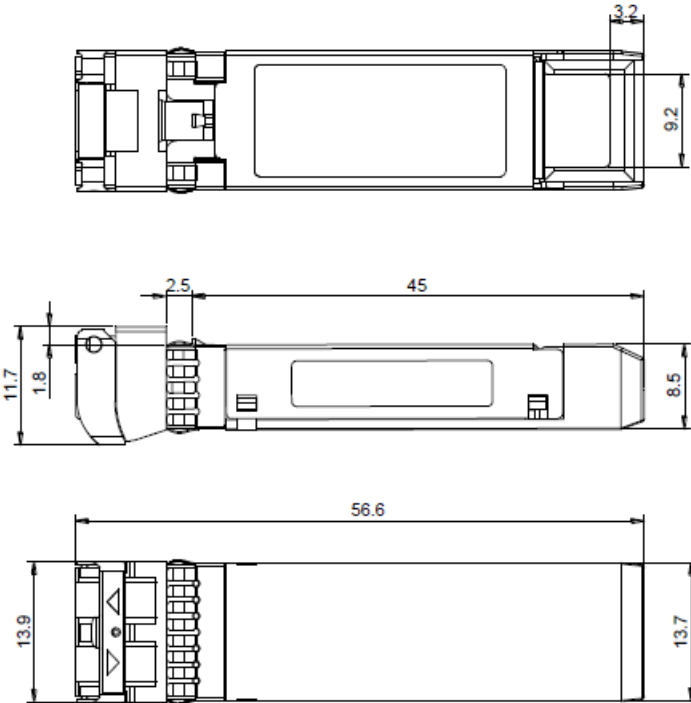

About Us:

Proline Options is one of North America's leading providers of transceivers and high speed cabling. With a reputation for quality, tested products that cover the connectivity spectrum, Proline Options has a solution for you regardless of the specification.

At Proline Options, every product is tested in its intended application - never batch or spec tested only. We run bandwidth, distance and IOS network tests. We have documented an impressive 0.03% failure rate over the last 10 years. To continue this rate of success we invest millions annually in our own on-site testing lab.



Tel: 855.933.3223

Email: sales@prolineoptions.com

Email: techsupport@prolineoptions.com

Web: <https://www.prolineoptions.com>