

1061480090-01-PRO

ADVA® 1061480090-01 Compatible TAA Compliant 100GBase-SR10 CFP2 Transceiver (MMF, 850nm, 150m, DOM, 0 to 70C, MPO)

Features

- CFP MSA 1.0 Compliance
- MPO Connector
- Commercial Temperature 0 to 70 Celsius
- Multi-mode Fiber
- Hot Pluggable
- Excellent ESD Protection
- Metal with Lower EMI
- RoHS Compliant and Lead Free



Applications:

- 100GBase Ethernet
- Access and Enterprise

Product Description

This ADVA® 1061480090-01 compatible CFP2 transceiver provides 100GBase-SR10 throughput up to 150m over multi-mode fiber (MMF) using a wavelength of 850nm via an MPO connector. It is guaranteed to be 100% compatible with the equivalent ADVA® transceiver. This easy to install, hot swappable transceiver has been programmed, uniquely serialized and data-traffic and application tested to ensure that it will initialize and perform identically. Digital optical monitoring (DOM) support is also present to allow access to real-time operating parameters. This transceiver is Trade Agreements Act (TAA) compliant. We stand behind the quality of our products and proudly offer a limited lifetime warranty.

Proline's transceivers are RoHS compliant and lead-free.

TAA refers to the Trade Agreements Act (19 U.S.C. & 2501-2581), which is intended to foster fair and open international trade. TAA requires that the U.S. Government may acquire only "U.S. – made or designated country end products.



Absolute Maximum Ratings

Parameter	Symbol	Min.	Typ	Max.	Unit
Maximum Supply Voltage	V _{CC}	-0.5		3.6	V
Storage Temperature	T _S	-40		85	°C
Operating Case Temperature	T _C	0		70	°C
Relative Humidity	R _H	0		85	%
Data Rate	D _R		103	112	Gb/s
Receiver Damage Threshold per Lane	PRdmg	5			

Electrical Characteristics

Parameter	Symbol	Min.	Typ.	Max.	Unit	Notes
Power Supply Voltage	V _{CC}	3.14		3.47	V	
Power Consumption	P _{DISS}			4	W	
Transmitter (per lane)						
Data Rate Per Lane	DRPL		10.3125	11.1810	Gb/s	1
Input voltage tolerance	V _{IN}	-0.3		4	V	
Differential data input swing	V _{IN,PP}	120		1200	mVpp	2
Differential input threshold	V _{IN,TH}		50		mV	
J2 Jitter Tolerance	JT2	0.17			UI	
J9 Jitter Tolerance	JT9	0.29			UI	
Receiver (per lane)						
Output voltage	V _{OUT}	-0.3		4.0	V	
Differential data output swing	V _{OUT,PP}	300		800	mVpp	3
output voltage (RMS)	PSEN2			7.5	mV	
Termination mismatch at 1 MHz	PPx			5	%	
Output rise time and fall time	T _r , T _f		28		Ps	4
J2 Jitter output	JOT2			0.42	UI	
J9 Jitter output	JOT9			0.65	UI	
Power Supply Ripple Tolerance	PRS	Per CFP MSA			mVpp	

Notes:

1. +/- 100ppm at 10.3125 Gb/s and +/-20ppm at 11.1810 Gb/s.
2. After internal AC coupling. Self-biasing 100Ω differential input.
3. AC coupled with 100Ω differential output impedance. Limiting output.
4. 20%~80%

Optical Characteristics ($T_{OP} = 0$ to 70 °C, $V_{CC} = 3.13$ to 3.47 V)

Parameter	Symbol	Min.	Typ.	Max.	Unit	Notes
Transmitter (per lane)						
Data Rate Per Lane	D_{RPL}		10.3125	11.1810	Gb/s	1
Center wavelength	λ	840	850	860	nm	
RMS Spectral Width	$\Delta\lambda$			0.65	nm	
Average Power per Lane	P_{AVEp}	-8		1	dBm	
Transmit OMA per Lane	P_{OMA}	-6		3.0	dBm	2
Average launch Power of OFF	D_P			-30	dB	
Peak Power per Lane	P_P			4.0	dBm	
TDP per Lane	T_{DP}			4	dBm	
Extinction Ratio	ER	3.0			dB	
Return Loss Tolerance				12	dB	
Relative Intensity Noise	R_{IN}			-128	dB/Hz	3
Transmitter eye mask definition {X1, X2, X3, Y1, Y2, Y3}		0.23, 0.34, 0.43, 0.27, 0.35, 0.4				
Receiver (per lane)						
Center wavelength	λ	840	850	860	nm	
Receiver Sensitivity per Lane	P_{SEN1}			-9.9	dBm	4
Receiver Sensitivity (OMA) per Lane	P_{SEN2}			-5.4	dBm	
Peak Power, per lane	P_{PX}			4	dBm	
Overload, per lane	P_{AVE}	1			dBm	
Receiver Reflectance	R_{RX}			-12	dB	
Dispersion penalty, per lane	T_{DP}			1.9	dB	
Stressed eye J2 jitter, per Lane	J_{E2P}		0.35		UI	
Stressed eye J9 jitter, per Lane	J_{E9P}		0.47		UI	
Jitter tolerance [OMA], per lane	J_{TP}		-5.4		dBm	
LOS De-Assert	P_a	-11			dBm	
LOS Assert	P_d			-25	dBm	
LOS Hysteresis	$P_d - P_a$	0.5			dB	

Notes:

1. Transmitter consists of 10 lasers operating at a maximum rate of 11.1810 Gb/s each.
2. Even if TDP is <0.9dB, the OMA min must exceed this value.
3. RIN is scaled by $10 \cdot \log(10/4)$ to maintain SNR outside of transmitter.
4. Measured using DUT Tx and DUT Rx; no golden transmitters shall be used.

Pin Descriptions

The CFP2 connector has 104 pins which are arranged in Top and Bottom rows.

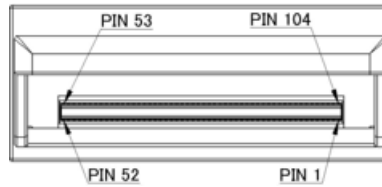

Pin #	Description	Pin #	Description
1	GND	104	GND
2	TX9n	103	TX7n
3	TX9p	102	TX7p
4	GND	101	GND
5	TX8n	100	TX6n
6	TX8p	99	TX6p
7	3.3V_GND	98	GND
8	3.3V_GND	97	TX5n
9	3.3V	96	TX5p
10	3.3V	95	GND
11	3.3V	94	TX4n
12	3.3V	93	TX4p
13	3.3V_GND	92	GND
14	3.3V_GND	91	TX3n
15	VND_IO_A	90	TX3p
16	VND_IO_B	89	GND
17	PRG_CNTL1	88	TX2n
18	PRG_CNTL2	87	TX2p
19	PRG_CNTL3	86	GND
20	PRG_ALARM1	85	TX1n
21	PRG_ALARM2	84	TX1p
22	PRG_ALARM3	83	GND
23	GND	82	TX0n
24	TX_DIS	81	TX0p
25	RX_LOS	80	GND
26	MOD_LOPWR	79	(REFCLKn)
27	MOD_ABS	78	(REFCLKp)
28	MOD_RSTn	77	GND
29	GLB_ALARMn	76	RX7n
30	GND	75	RX7p
31	MDC	74	GND
32	MDIO	73	RX6n
33	PRTADR0	72	RX6p
34	PRTADR1	71	GND

35	PRTADR2	70	RX5n
36	VND_IO_C	69	RX5p
37	VND_IO_D	68	GND
38	VND_IO_E	67	RX4n
39	3.3V_GND	66	RX4p
40	3.3V_GND	65	GND
41	3.3V	64	RX3n
42	3.3V	63	RX3p
43	3.3V	62	GND
44	3.3V	61	RX2n
45	3.3V_GND	60	RX2p
46	3.3V_GND	59	GND
47	RX9n	58	RX1n
48	RX9p	57	RX1p
49	GND	56	GND
50	RX8n	55	RX0n
51	RX8p	54	RX0p
52	GND	53	GND

Optical Lane Assignment (front view of MPO receptacle)

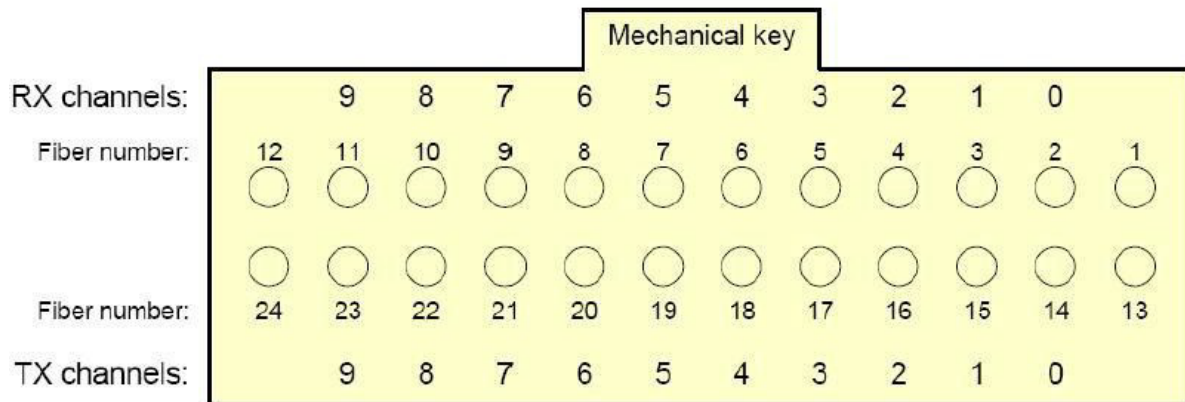

Fiber #	Channel	Electrical Pin	Fiber #	Channel	Electrical Pin
1	Unused		13	Unused	
2	RX0	54,55	14	TX0	81,82
3	RX1	57,58	15	TX1	84,85
4	RX2	60,61	16	TX2	87,88
5	RX3	63,64	17	TX3	90,91
6	RX4	66,67	18	TX4	93,94
7	RX5	69,70	19	TX5	96,97
8	RX6	72,73	20	TX6	99,100
9	RX7	75,76	21	TX7	102,103
10	RX8	51,50	22	TX8	6,5
11	RX9	48,47	23	TX9	3,2
12	Unused		24	Unused	

Functional Diagram

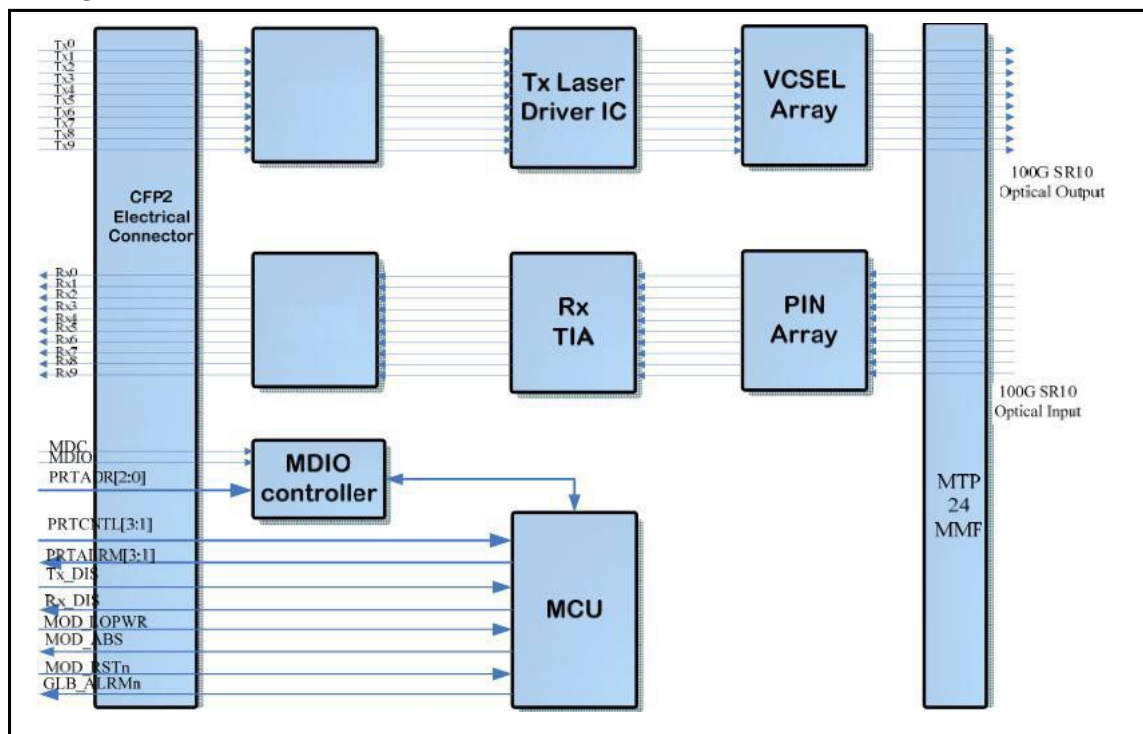

Mechanical Specifications

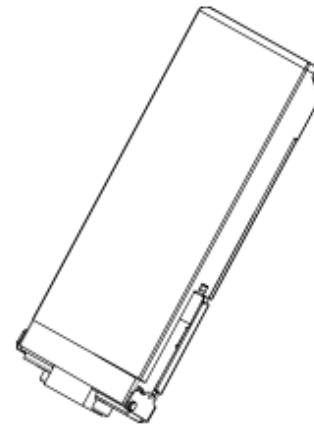
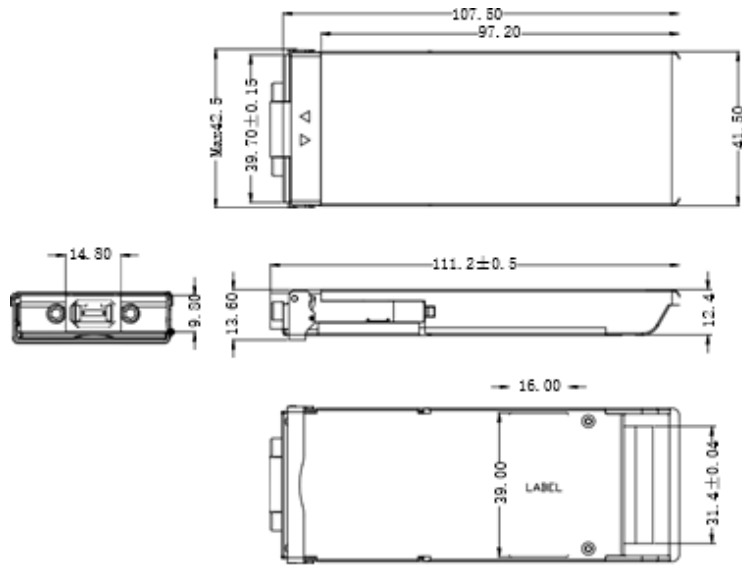

Tolerance without indication is ±0.2mm
Units

About Us:

Proline Options is one of North America's leading providers of transceivers and high speed cabling. With a reputation for quality, tested products that cover the connectivity spectrum, Proline Options has a solution for you regardless of the specification.

At Proline Options, every product is tested in its intended application - never batch or spec tested only. We run bandwidth, distance and IOS network tests. We have documented an impressive 0.03% failure rate over the last 10 years. To continue this rate of success we invest millions annually in our own on-site testing lab.



Tel: 855.933.3223

Email: sales@prolineoptions.com

Email: techsupport@prolineoptions.com

Web: <https://www.prolineoptions.com>